

**TECHNICAL DATASHEET**



**Thermal Printer eXtendo® XF**

- Ultra Robust and Reliable
- Proven eXtendo functionality and tool box
- High-speed printing 250 mm/s
- Easy Servicing
- eezeetags® bagtag compatible
- Zebra KRx03 mount compatible



**TECHNICAL DATA  
General**

Dimensions (L x W x H)	133 mm x 96,5 mm x 74,5 mm
Technology	Thermal Direct Printing 203 dpi resolution
Supply Voltage	24 V DC +/- 10% 10 .. 15 VDC Option
Paper Width	58..60 mm 54 mm (with optional paper guides)
Printable width	56 mm / 448 dots
Paper Thickness	50 .. 160 g/sqm full-cut 50 .. 120 g/sqm partial/ full-cut
Paper Style	Roll, fan-folded, labels, linerless labels
Paper Roll Capacity	150 mm (6"), 200 mm (8")
Cutter	Guillotine Type Full cut and partial cut
Paper Loading	Auto detect and auto load with auto data sheet print
Black Mark Control	Automatic sensor calibration Blackmarks or hole marks
Mounting	Zebra mount compatible (3 hub pins or M3 threads) Customizable mount options

**TECHNICAL DATA  
Performance and Life**

Print Speed	Up to 250 mm/s
Reliability	Printhead: 150 km, 150 mio dots Cutter: 1.5/1.0 mio cuts Full/Partial cut
Interface	USB2.0, RS232 (Mini USB, JST 6-pin)
Barcodes	UPC-A/E, EAN-13, EAN-8, Code 39, Interleaved 2 of 5, Code 128, Codabar, PDF 417, QR, Datamatrix, Aztec
Operating System	Windows, Linux (64bit, ARM)
Environmental Conditions	Operating -25° .. 65°C; 20 .. 85% RH (non-condensing) Storage -30° .. 75°C
Shock and Vibration	Vibration: DIN EN 60068-2-6 Shock: DIN EN 60068-2-27 (for shipping purposes)
Approvals	CE, UL pending

Specifications subject to change without notice.

Part No.:	© Hengstler GmbH Umlandstr. 49 D-78554 Aldingen/ Germany ☎ +49 74 24 -89 0 Fax +49 74 24 - 89 500 E-mail: info@hengstler.com Internet: www.hengstler.com	Page
Edition: June 2022		1/2

## TECHNICAL DATASHEET

### Thermal Printer eXtendo® XF

#### DIMENSIONAL DRAWING

Dimensions in mm

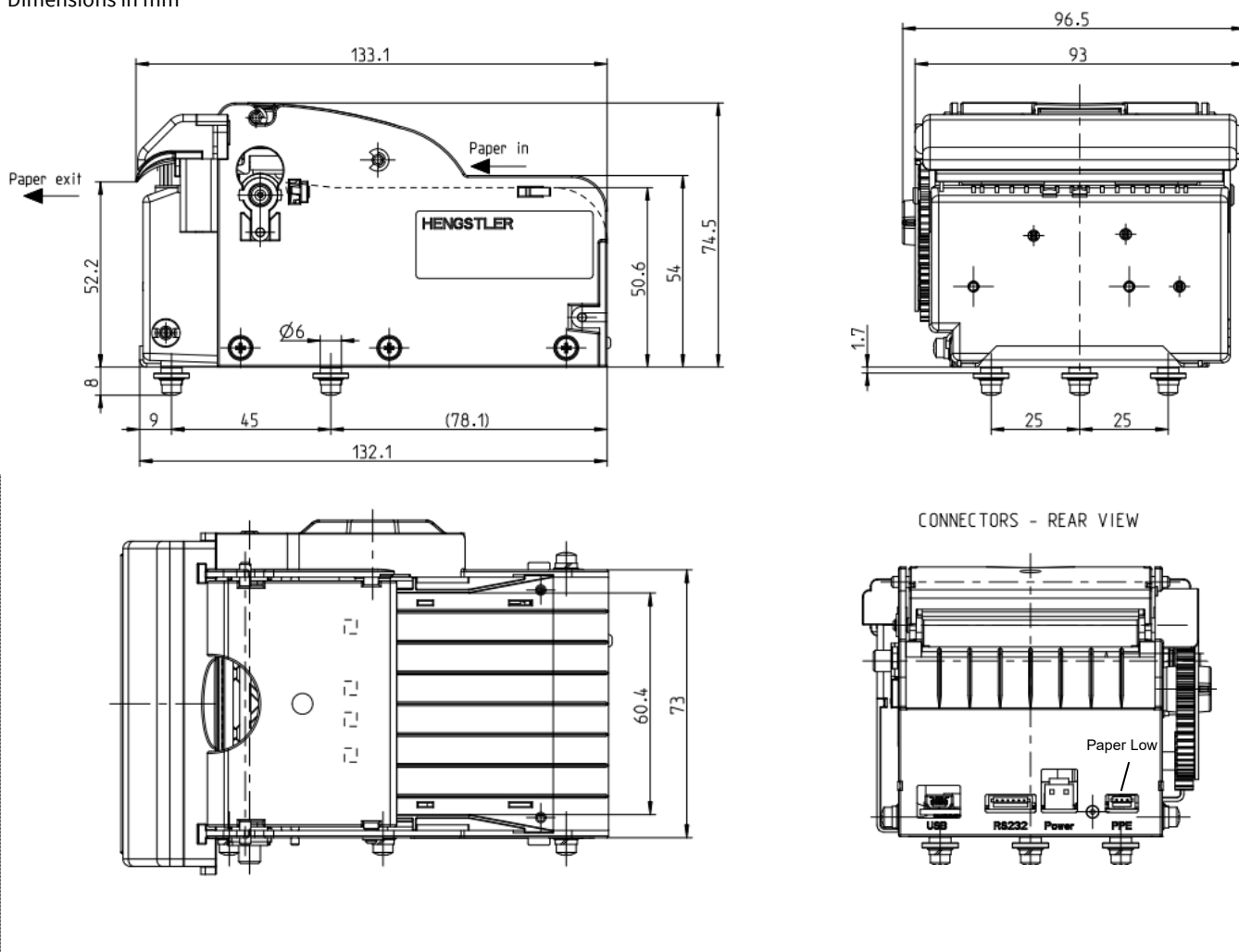

#### ACCESSORIES

Accessories	Part No.
Paper Roll Holder Kit	E1684201
Mounting Brackets (Kit of 5 pairs)	E1684202
Paper Guides (Kit of 5 pairs)	E1684203
Paper Low Sensor Kit (330 mm or 550 mm cable length)	E1684115 or E1684133
DC power cable	E1684530
USB Data cable	0684102
RS232 Data cable	E1684527

#### Documentation

Documentation	Part No.
Operating Manual	D-684-399
Dimensions Printer	D-684-398
Dimensions Printer + Paper Roll Holder	D-684-396

Specifications subject to change without notice.

Part No.:	© Hengstler GmbH Umlandstr. 49 D-78554 Aldingen/ Germany +49 74 24 -89 0 Fax +49 74 24 - 89 500 E-mail: info@hengstler.com Internet: www.hengstler.com	Page
Edition: June 2022		2/2