

* : TOLERANCE BETWEEN DOWELS $\pm 0,02$, BETWEEN SCREW HOLES $\pm 0,1$
 ** : AREA TO ACCESS ANGLE ADJUSTMENT

Bore \varnothing	Holding moment	Clamping moment (0,5 MPa)	Weight (clamping arm not included)
50 mm	1250 Nm	280 Nm	2,5 Kg

Min./Max. operating pressure: **0,4 / 0,6 MPa**
 Operating temperature: **5° ÷ 45° C**
 Opening angle: **adjustable**
 Without arm
 Electronic sensor with M12 swivel connector, from 0° to 90°
 Supply voltage: **10 ÷ 30 Vdc**
 IP code: **IP 65**
 Pneumatic ports on both sides

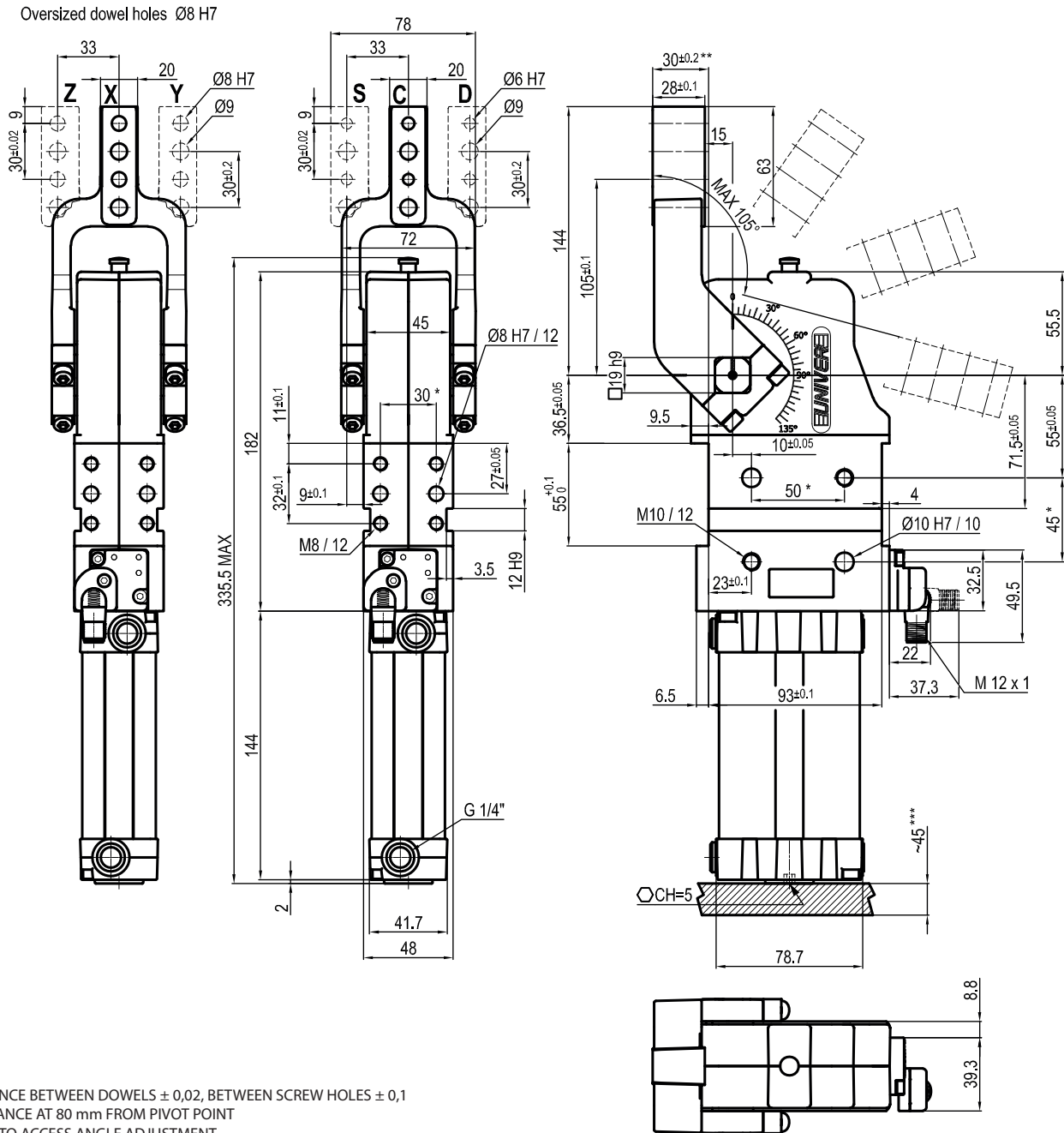

* : TOLERANCE BETWEEN DOWELS $\pm 0,02$, BETWEEN SCREW HOLES $\pm 0,1$
 ** : TOLERANCE AT 80 mm FROM PIVOT POINT
 *** : AREA TO ACCESS ANGLE ADJUSTMENT

UCBP500 __ K0
6 7
6 ARM STYLE

C = Central
 D = Right
 S = Left

7 ARM TYPE

A = Aluminium
 S = Steel

Bore Ø	Holding moment	Clamping moment (0,5 MPa)	Weight (clamping arm not included)
50 mm	1250 Nm	280 Nm	2,5 Kg

Min./Max. operating pressure: **0,4 / 0,6 MPa**
 Operating temperature: **5° ÷ 45° C**
 Opening angle: **adjustable from 0° to 105°**
 Arm position: **180°**
 Electronic sensor with M12 swivel connector, from 0° to 90°
 Supply voltage: **10 ÷ 30 Vdc**
 IP code: **IP 65**
 Pneumatic ports on both sides

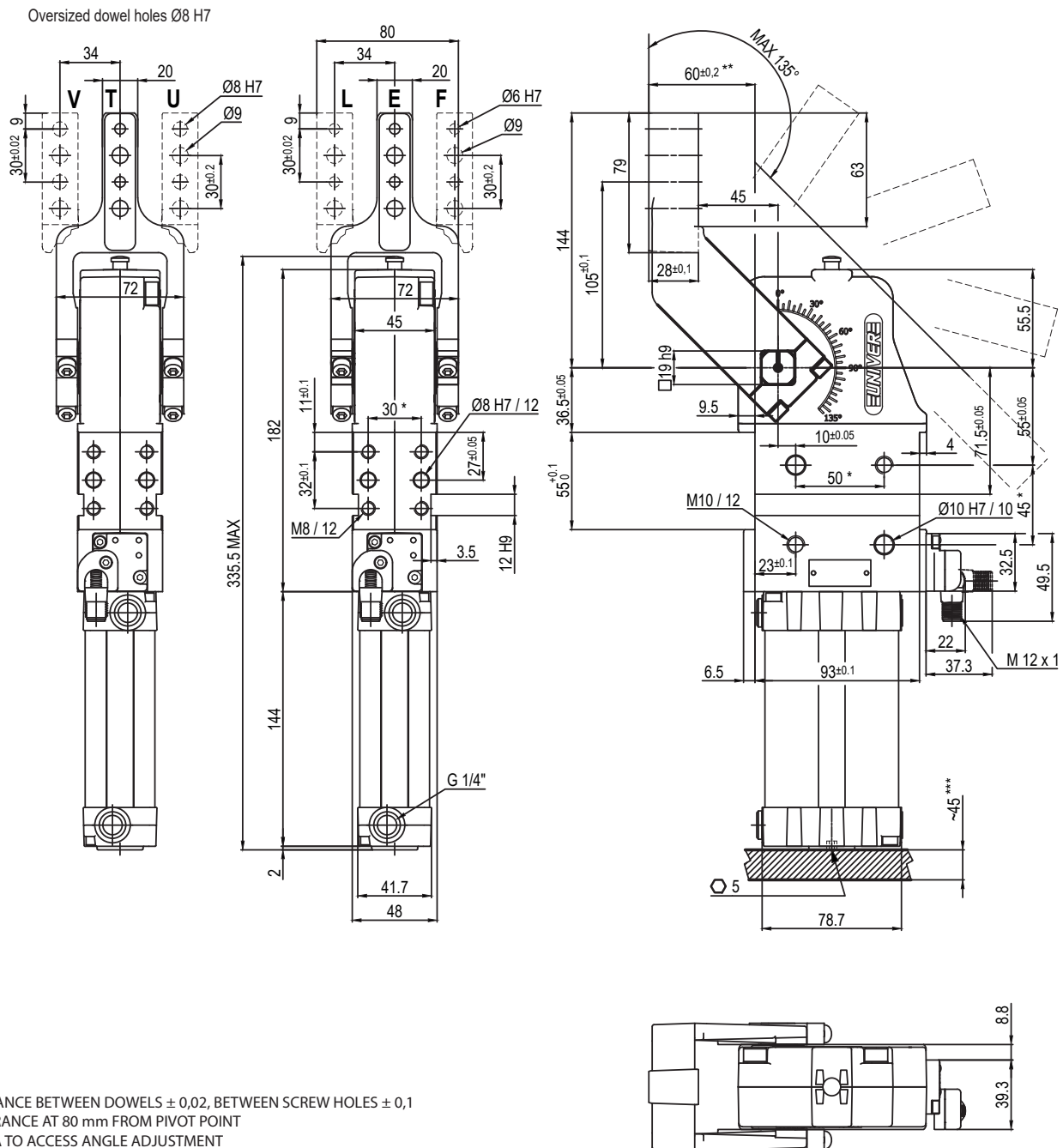
UCBP500 _ _ K0
6 7
6 ARM STYLE

 E = Central
 F = Right
 L = Left

7 ARM TYPE

 A = Aluminium
 S = Steel

Bore Ø	Holding moment	Clamping moment (0,5 MPa)	Weight (clamping arm not included)
50 mm	1250 Nm	280 Nm	2,5 Kg

 Min./Max. operating pressure: **0,4 / 0,6 MPa**
 Operating temperature: **5° ÷ 45° C**
 Opening angle: **adjustable from 0° to 135°**
 Arm position: **180°**
 Electronic sensor with M12 swivel connector, from 0° to 90°
 Supply voltage: **10 ÷ 30 Vdc**
 IP code: **IP 65**
 Pneumatic ports on both sides

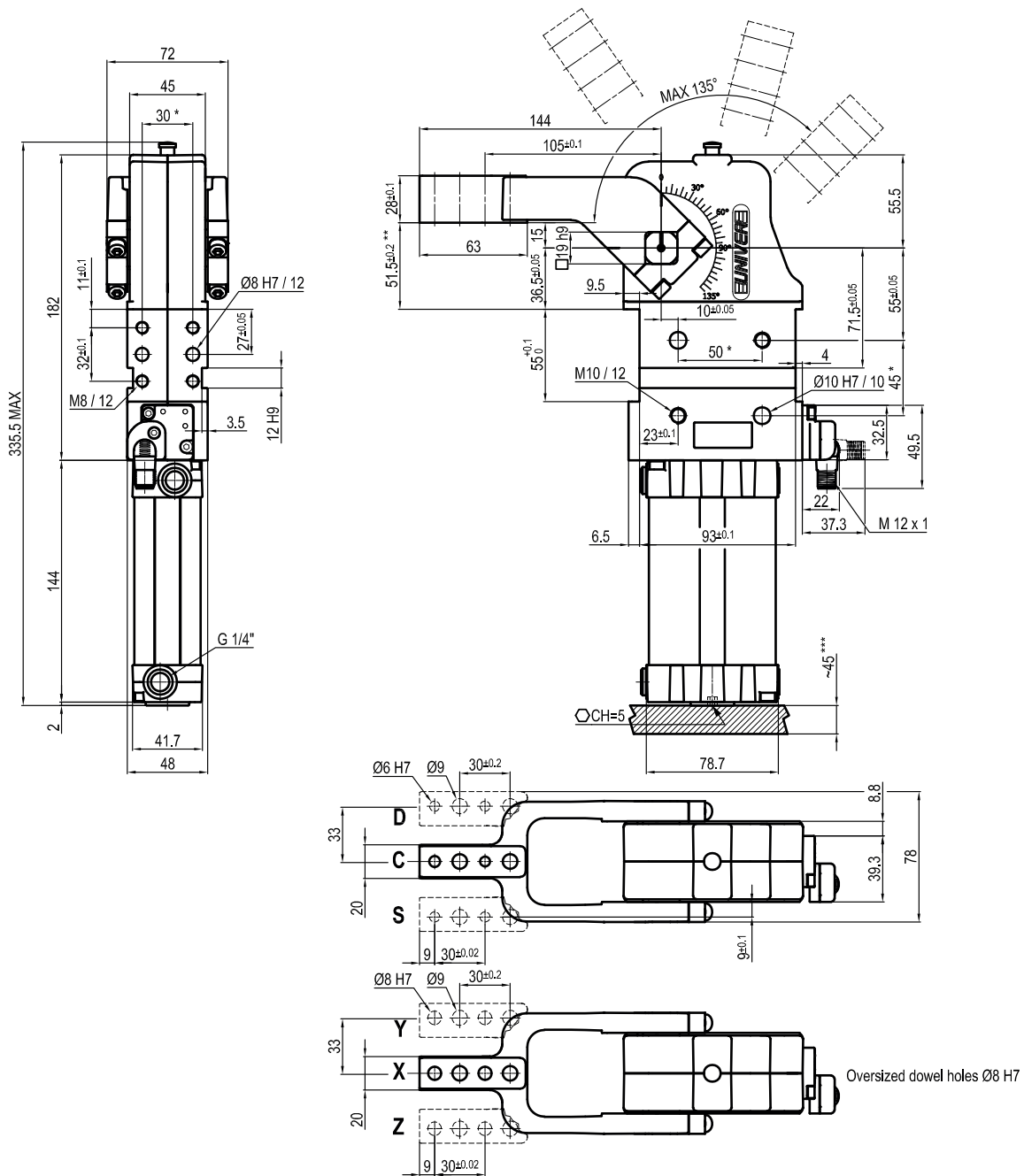

* : TOLERANCE BETWEEN DOWELS $\pm 0,02$, BETWEEN SCREW HOLES $\pm 0,1$

** : TOLERANCE AT 80 mm FROM PIVOT POINT

*** : AREA TO ACCESS ANGLE ADJUSTMENT

UCBP50V __ K0

6 7

6 ARM STYLE

C = Central
D = Right
S = Left

7 ARM TYPE

A = Aluminium
S = Steel

Bore \varnothing	Holding moment	Clamping moment (0,5 MPa)	Weight (clamping arm not included)
50 mm	1250 Nm	280 Nm	2,5 Kg

Min./Max. operating pressure: **0,4 / 0,6 MPa**

Operating temperature: **5° ÷ 45° C**

Opening angle: **adjustable from 0° to 135°**

Arm position: **90°**

Electronic sensor with M12 swivel connector, from 0° to 90°

Supply voltage: **10 ÷ 30 Vdc**

IP code: **IP 65**

Pneumatic ports on both sides

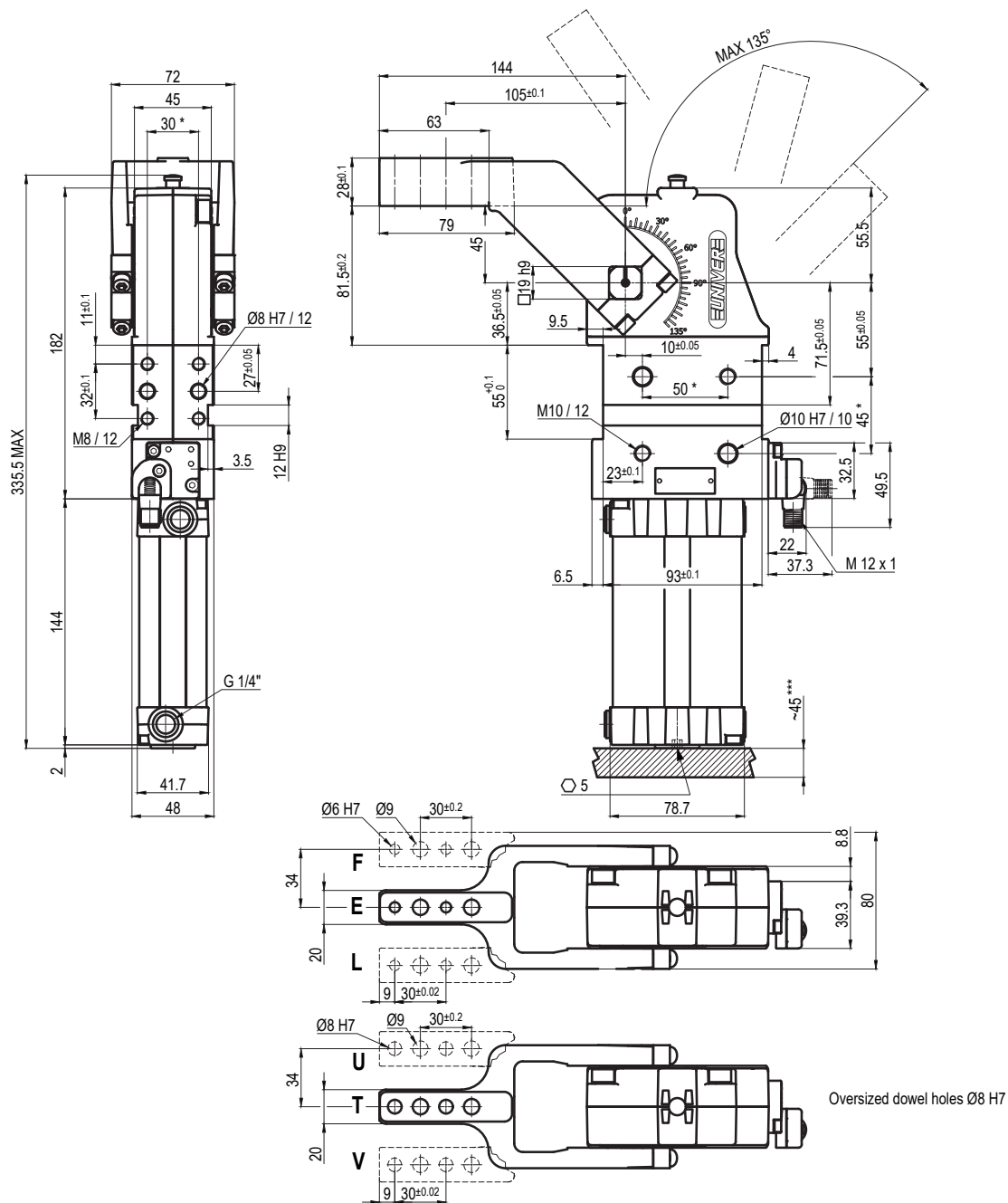

* : TOLERANCE BETWEEN DOWELS ± 0,02, BETWEEN SCREW HOLES ± 0,1

** : TOLERANCE AT 80 mm FROM PIVOT POINT

*** : AREA TO ACCESS ANGLE ADJUSTMENT

UCBP50V __ K0
6 ARM STYLE

7 ARM TYPE

6 7

E = Central
F = Right
L = Left

A = Aluminium
S = Steel

Bore Ø	Holding moment	Clamping moment (0,5 MPa)	Weight (clamping arm not included)
50 mm	1250 Nm	280 Nm	2,5 Kg

Min./Max. operating pressure: **0,4 / 0,6 MPa**

Operating temperature: **5° ÷ 45° C**

Opening angle: **adjustable from 0° to 135°**

Arm position: **90°**

Electronic sensor with M12 swivel connector, from 0° to 90°

Supply voltage: **10 ÷ 30 Vdc**

IP code: **IP 65**

Pneumatic ports on both sides