

\* : TOLERANCE BETWEEN DOWELS  $\pm 0.02$ , BETWEEN SCREW HOLES  $\pm 0.1$   
 \*\* : AREA TO ACCESS ANGLE ADJUSTMENT

Size $\varnothing$	Cylinder bore $\varnothing$	Holding moment	Clamping moment (0,5 MPa)	Weight (clamping arm not included)
63 mm	50 mm	1750 Nm	380 Nm	3,2 Kg

Min./Max. operating pressure: **0,4 / 0,6 MPa**  
 Operating temperature: **5° ÷ 45° C**  
 Opening angle: **adjustable**  
 Without arm  
 Electronic sensor with M12 swivel connector, from 0° to 90°  
 Supply voltage: **10 ÷ 30 Vdc**  
 IP code: **IP 65**  
 Pneumatic ports on both sides

Subject to technical modifications without notice

Rev. 01 27.01.22

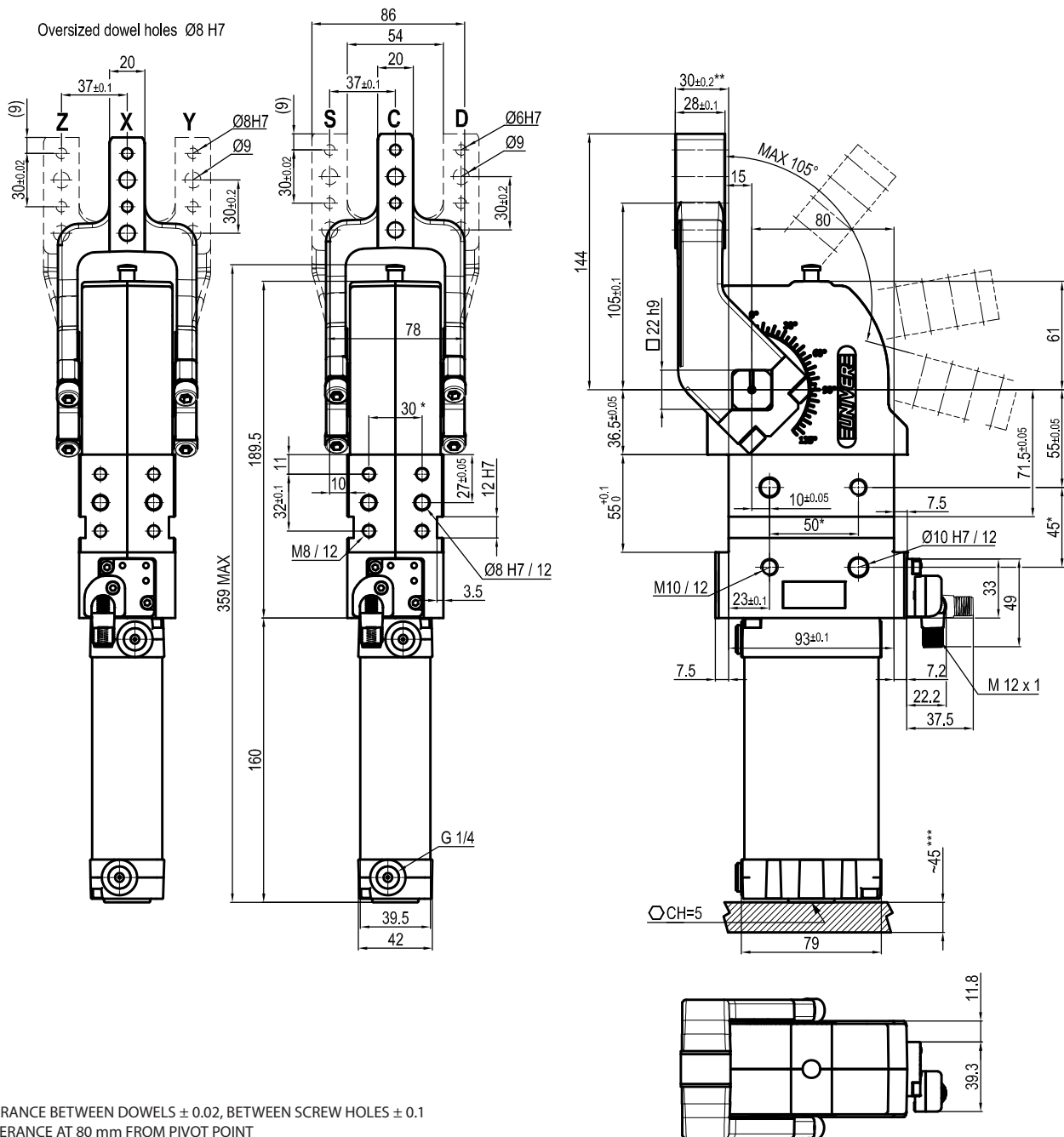

\* : TOLERANCE BETWEEN DOWELS ± 0.02, BETWEEN SCREW HOLES ± 0.1

\*\* : TOLERANCE AT 80 mm FROM PIVOT POINT

\*\*\* : AREA TO ACCESS ANGLE ADJUSTMENT

**UABP630 \_\_ K0**
**6** ARM STYLE

**7** ARM TYPE

**6 7**

C = Central  
D = Right  
S = Left

A = Aluminium  
S = Steel

Size Ø	Cylinder bore Ø	Holding moment	Clamping moment (0,5 MPa)	Weight (clamping arm not included)
63 mm	50 mm	1750 Nm	380 Nm	3,2 Kg

Min./Max. operating pressure: **0,4 / 0,6 MPa**

Operating temperature: **5° ÷ 45° C**

Opening angle: **adjustable from 0° to 105°**

Arm position: **180°**

Electronic sensor with M12 swivel connector, from 0° to 90°

Supply voltage: **10 ÷ 30 Vdc**

IP code: **IP 65**

Pneumatic ports on both sides

Subject to technical modifications without notice

Rev. 02 27.01.22

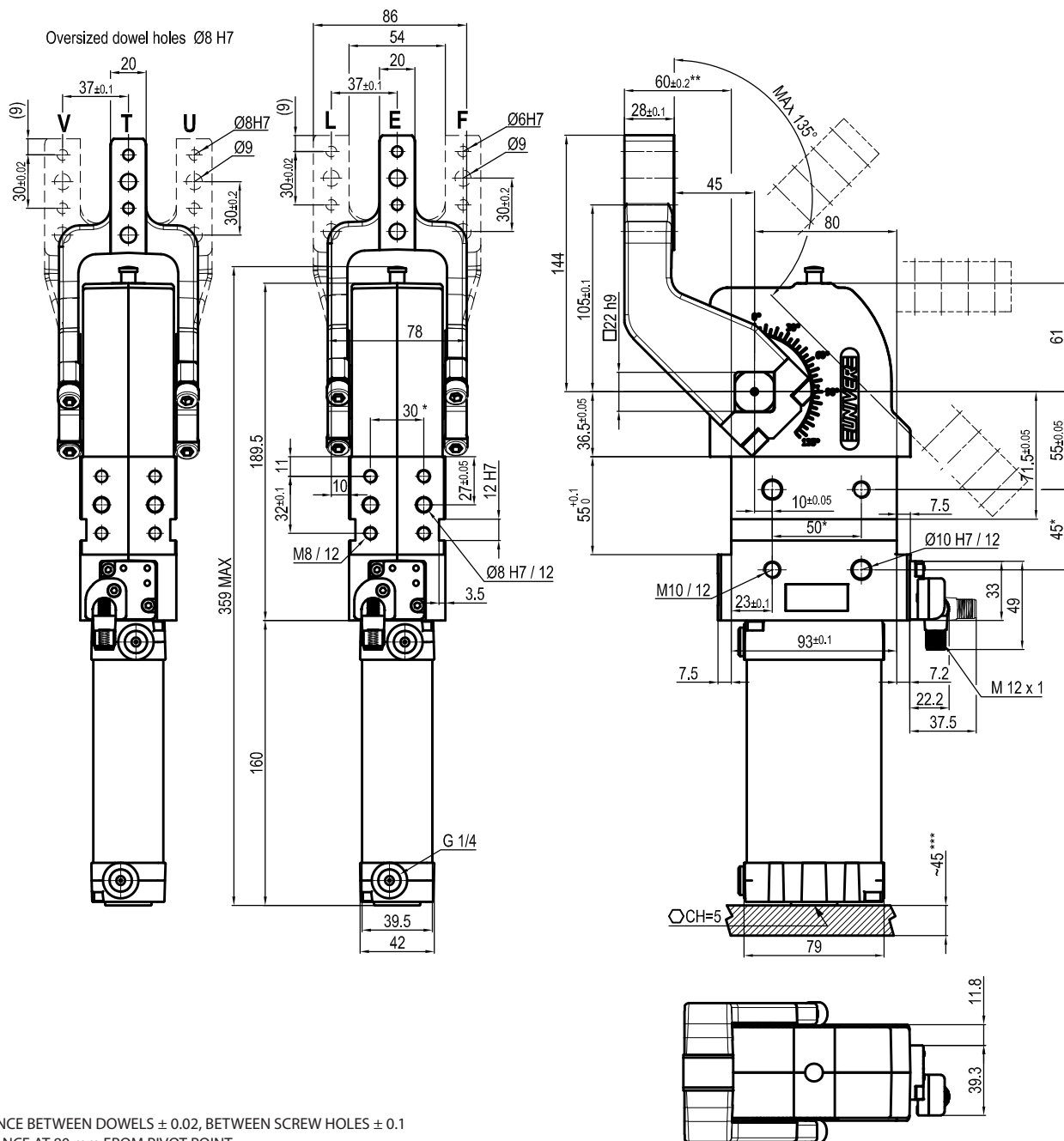

\* : TOLERANCE BETWEEN DOWELS  $\pm 0.02$ , BETWEEN SCREW HOLES  $\pm 0.1$

\*\* : TOLERANCE AT 80 mm FROM PIVOT POINT

\*\*\* : AREA TO ACCESS ANGLE ADJUSTMENT

**UABP630 \_\_ K0**
**6 7**
**6** ARM STYLE

E = Central  
F = Right  
L = Left

**7** ARM TYPE

A = Aluminium  
S = Steel

Size $\varnothing$	Cylinder bore $\varnothing$	Holding moment	Clamping moment (0,5 MPa)	Weight (clamping arm not included)
63 mm	50 mm	1750 Nm	380 Nm	3,2 Kg

Min./Max. operating pressure: **0,4 / 0,6 MPa**

Operating temperature: **5° ÷ 45° C**

Opening angle: **adjustable from 0° to 135°**

Arm position: **180°**

Electronic sensor with M12 swivel connector, from 0° to 90°

Supply voltage: **10 ÷ 30 Vdc**

IP code: **IP 65**

Pneumatic ports on both sides

Subject to technical modifications without notice

Rev. 02 27.01.22

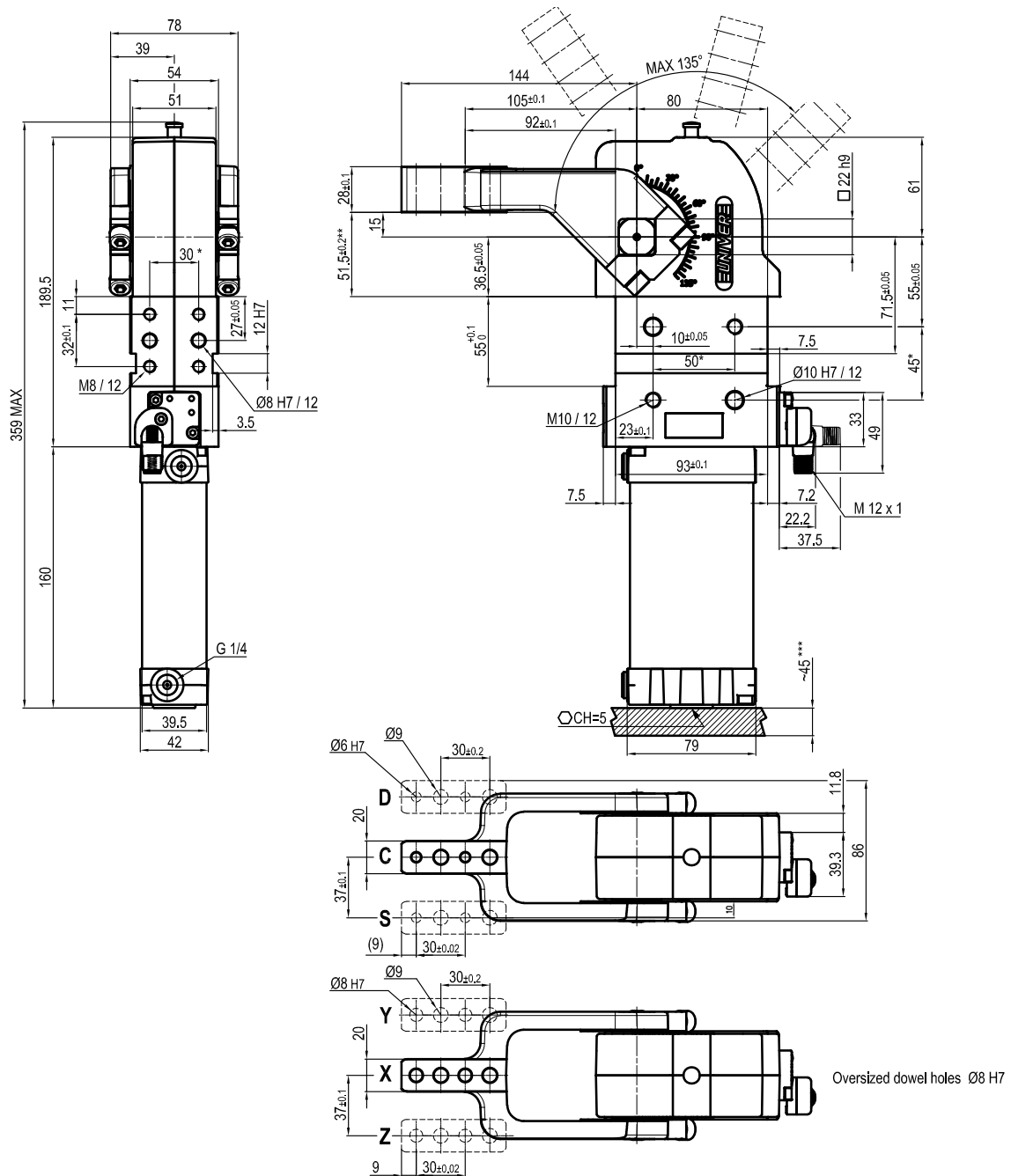

\* : TOLERANCE BETWEEN DOWELS  $\pm 0.02$ , BETWEEN SCREW HOLES  $\pm 0.1$   
 \*\* : TOLERANCE AT 80 mm FROM PIVOT POINT  
 \*\*\* : AREA TO ACCESS ANGLE ADJUSTMENT

**UABP63V \_\_ \_ K0**
**6** ARM STYLE

**7** ARM TYPE

**6 7**

C = Central  
 D = Right  
 S = Left

A = Aluminium  
 S = Steel

Size $\varnothing$	Cylinder bore $\varnothing$	Holding moment	Clamping moment (0,5 MPa)	Weight (clamping arm not included)
63 mm	50 mm	1750 Nm	380 Nm	3,2 Kg

Min./Max. operating pressure: **0,4 / 0,6 MPa**  
 Operating temperature: **5° ÷ 45° C**  
 Opening angle: **adjustable from 0° to 135°**  
 Arm position: **90°**  
 Electronic sensor with M12 swivel connector, from 0° to 90°  
 Supply voltage: **10 ÷ 30 Vdc**  
 IP code: **IP 65**  
 Pneumatic ports on both sides

Subject to technical modifications without notice

Rev. 02 27.01.22

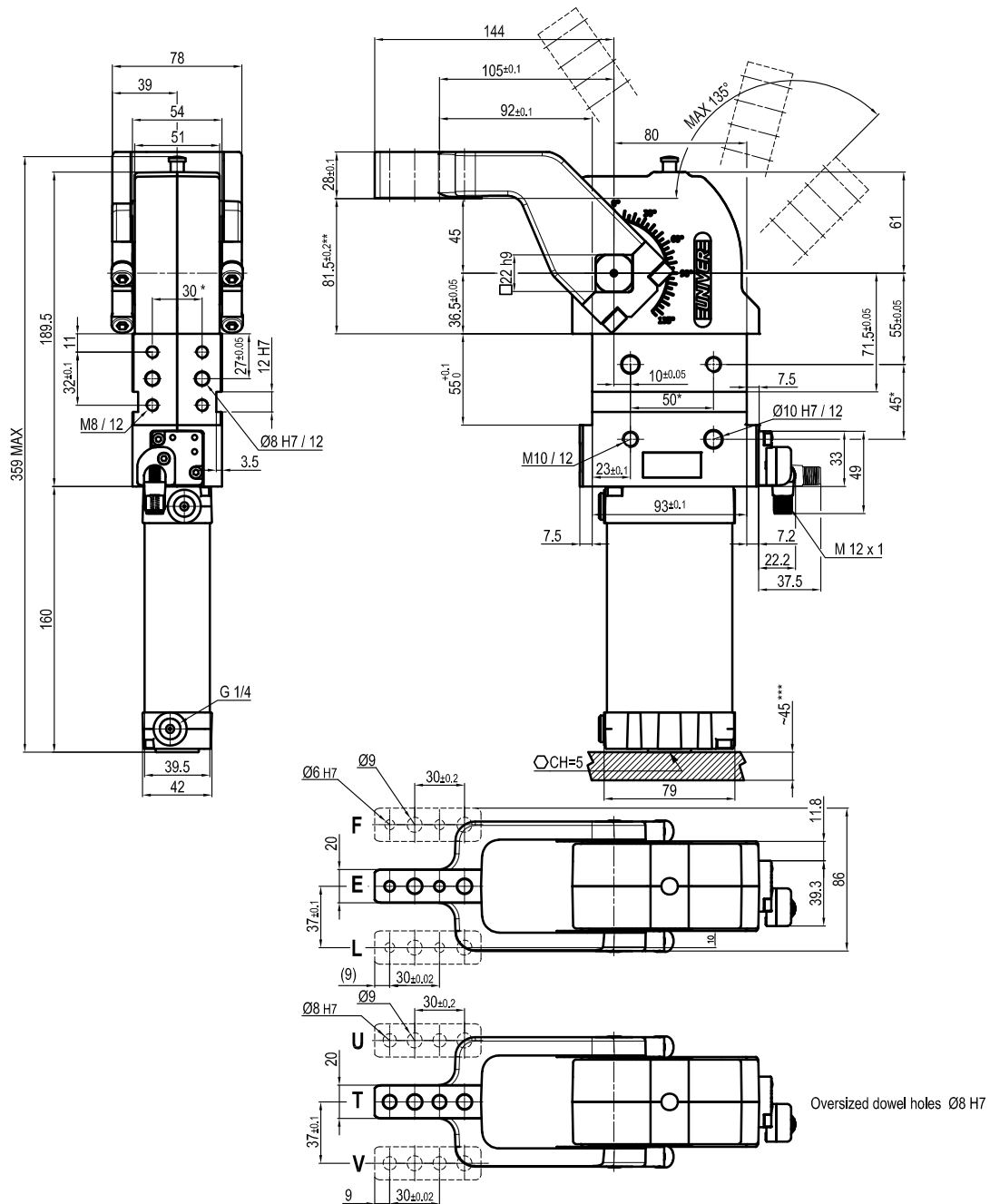

\* : TOLERANCE BETWEEN DOWELS ± 0.02, BETWEEN SCREW HOLES ± 0.1

\*\* : TOLERANCE AT 80 mm FROM PIVOT POINT

\*\*\* : AREA TO ACCESS ANGLE ADJUSTMENT

## UABP63V \_\_ K0

**6 7**

**6** ARM STYLE

E = Central  
F = Right  
L = Left

**7** ARM TYPE

A = Aluminium  
S = Steel

Size Ø	Cylinder bore Ø	Holding moment	Clamping moment (0,5 MPa)	Weight (clamping arm not included)
63 mm	50 mm	1750 Nm	380 Nm	3,2 Kg

Min./Max. operating pressure: **0,4 / 0,6 MPa**

Operating temperature: **5° ÷ 45° C**

Opening angle: **adjustable from 0° to 135°**

Arm position: **90°**

Electronic sensor with M12 swivel connector, from 0° to 90°

Supply voltage: **10 ÷ 30 Vdc**

IP code: **IP 65**

Pneumatic ports on both sides

Subject to technical modifications without notice

Rev. 02 27.01.22