

\*: TOLERANCE BETWEEN DOWELS  $\pm 0.02$ , BETWEEN SCREW HOLES  $\pm 0.1$   
 \*\*: AREA TO ACCESS ANGLE ADJUSTMENT

Size $\varnothing$	Cylinder bore $\varnothing$	Holding moment	Clamping moment (0,5 MPa)	Weight (clamping arm not included)
40 mm	32 mm	600 Nm	125 Nm	1,4 Kg

Min./Max. operating pressure: **0,4 / 0,6 MPa**  
 Operating temperature: **5° ÷ 45° C**  
 Opening angle: **adjustable**  
 Without arm  
 Electronic sensor with M12 swivel connector, from 0° to 90°  
 Supply voltage: **10 ÷ 30 Vdc**  
 IP code: **IP 65**

Subject to technical modifications without notice

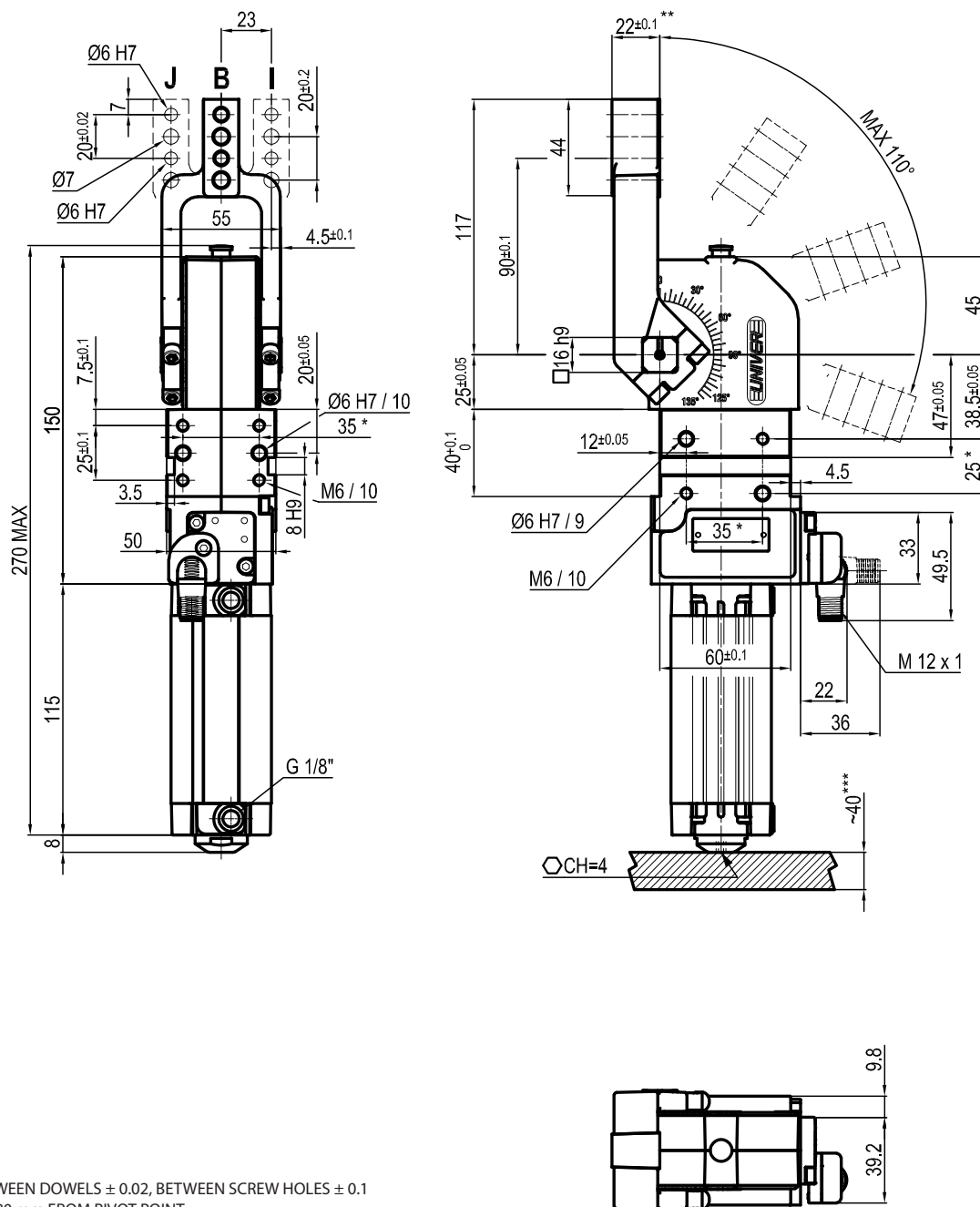

\* : TOLERANCE BETWEEN DOWELS ± 0.02, BETWEEN SCREW HOLES ± 0.1

\*\* : TOLERANCE AT 80 mm FROM PIVOT POINT

\*\*\* : AREA TO ACCESS ANGLE ADJUSTMENT

**UABP400 \_\_ K0**
**6** ARM STYLE

**7** ARM TYPE

**6 7**

B = Central  
I = Right  
J = Left

A = Aluminium  
S = Steel

Size Ø	Cylinder bore Ø	Holding moment	Clamping moment (0,5 MPa)	Weight (clamping arm not included)
40 mm	32 mm	600 Nm	125 Nm	1,4 Kg

Min./Max. operating pressure: **0,4 / 0,6 MPa**

Operating temperature: **5° ÷ 45° C**

Opening angle: **adjustable from 0° to 110°**

Arm position: **180°**

Electronic sensor with M12 swivel connector, from 0° to 90°

Supply voltage: **10 ÷ 30 Vdc**

IP code: **IP 65**

Subject to technical modifications without notice

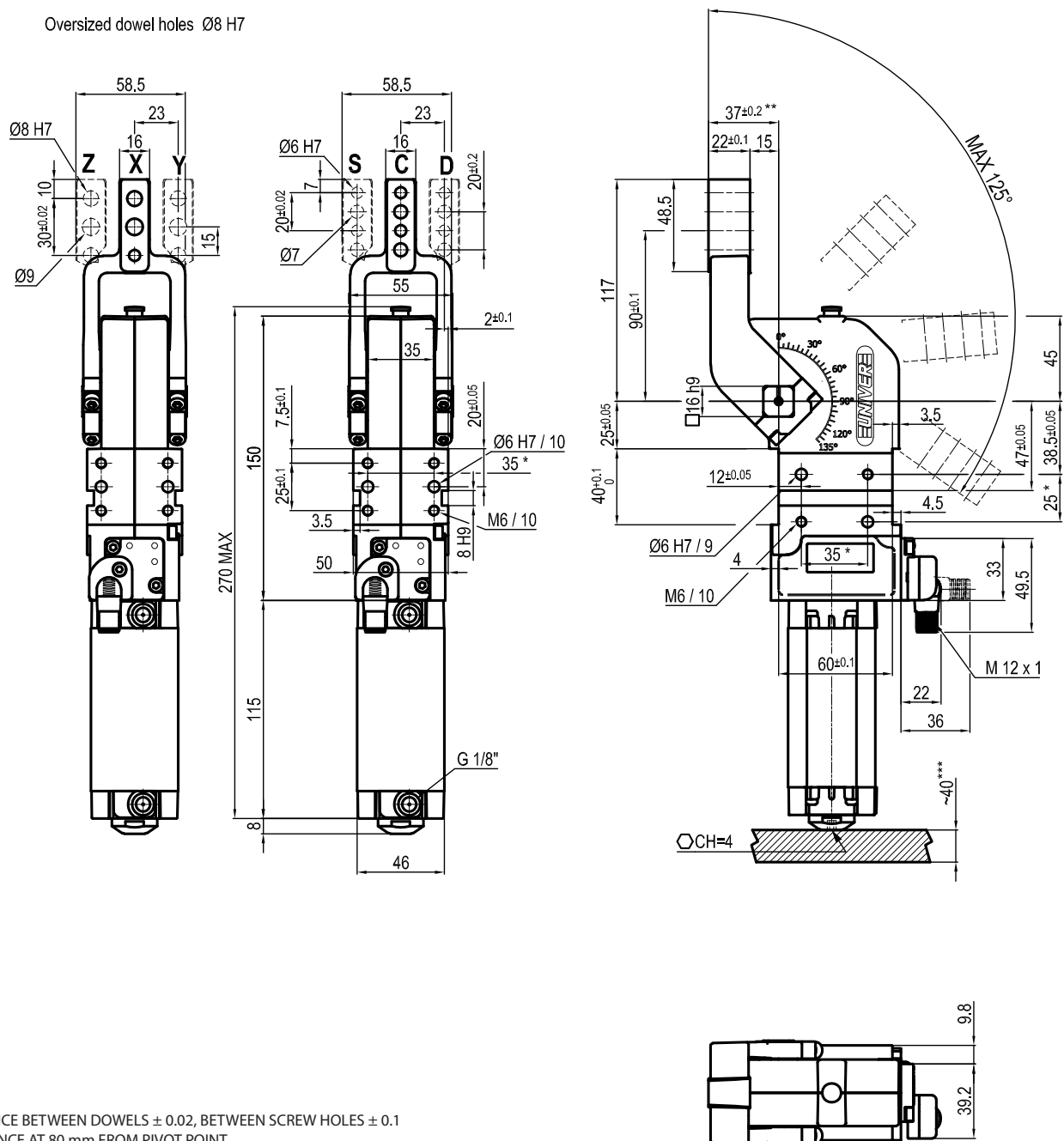
Oversized dowel holes  $\varnothing 8$  H7

 \*: TOLERANCE BETWEEN DOWELS  $\pm 0.02$ , BETWEEN SCREW HOLES  $\pm 0.1$ 

\*\*: TOLERANCE AT 80 mm FROM PIVOT POINT

\*\*: AREA TO ACCESS ANGLE ADJUSTMENT

**UABP400 \_\_ K0**
**6** ARM STYLE

**7** ARM TYPE

**6 7**

 C = Central  
 D = Right  
 S = Left

 A = Aluminium  
 S = Steel

Size $\varnothing$	Cylinder bore $\varnothing$	Holding moment	Clamping moment (0,5 MPa)	Weight (clamping arm not included)
40 mm	32 mm	600 Nm	125 Nm	1,4 Kg

 Min./Max. operating pressure: **0,4 / 0,6 MPa**

 Operating temperature: **5° ÷ 45° C**

 Opening angle: **adjustable from 0° to 125°**

 Arm position: **180°**

Electronic sensor with M12 swivel connector, from 0° to 90°

 Supply voltage: **10 ÷ 30 Vdc**

 IP code: **IP 65**

Subject to technical modifications without notice

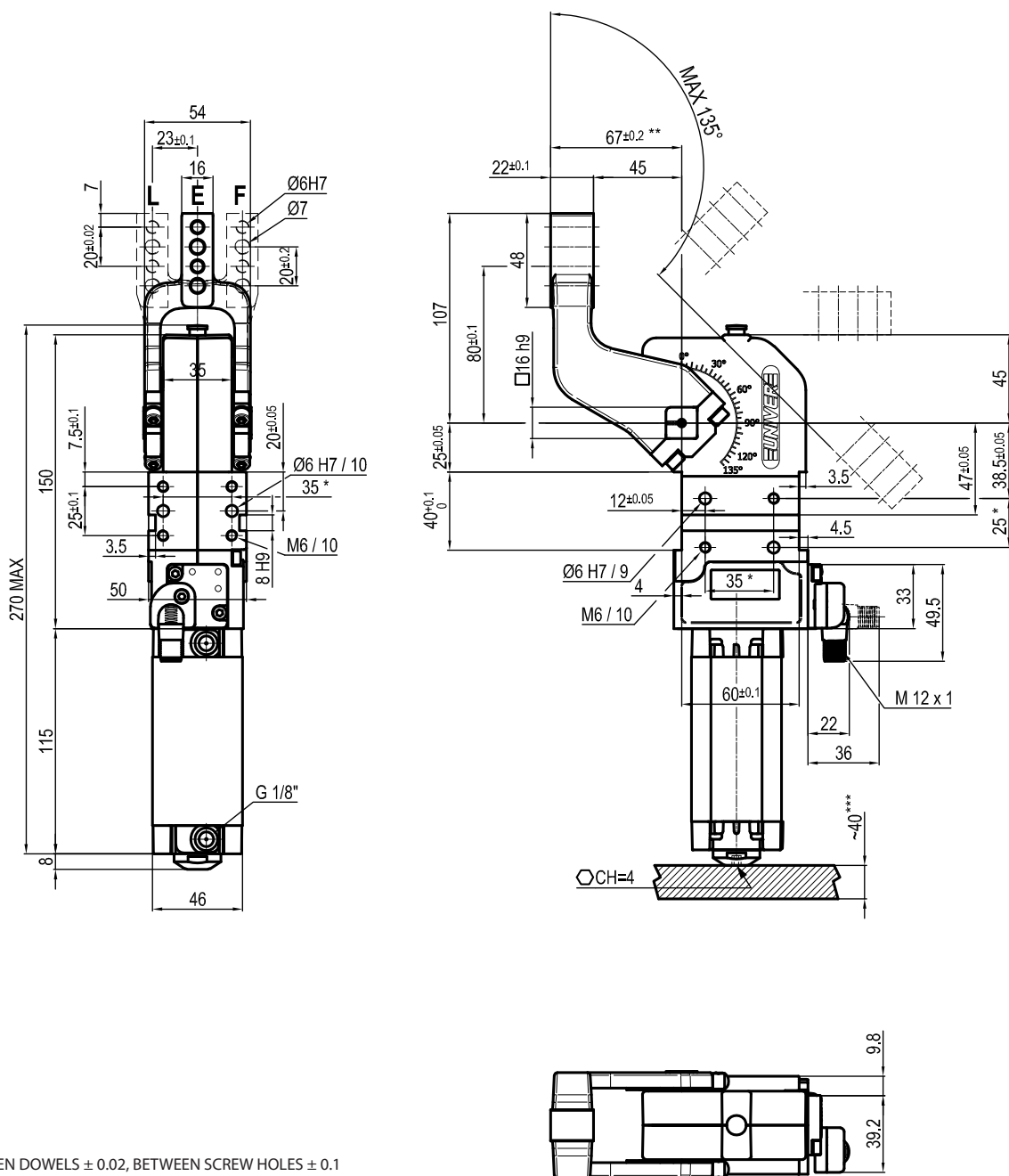

\* : TOLERANCE BETWEEN DOWELS  $\pm 0.02$ , BETWEEN SCREW HOLES  $\pm 0.1$   
 \*\* : TOLERANCE AT 80 mm FROM PIVOT POINT  
 \*\*\* : AREA TO ACCESS ANGLE ADJUSTMENT

**UABP400 \_\_ K0**
**6** ARM STYLE

**7** ARM TYPE

**6 7**

 E = Central  
 F = Right  
 L = Left

 A = Aluminium  
 S = Steel

Size $\varnothing$	Cylinder bore $\varnothing$	Holding moment	Clamping moment (0,5 MPa)	Weight (clamping arm not included)
40 mm	32 mm	600 Nm	125 Nm	1,4 Kg

Min./Max. operating pressure: **0,4 / 0,6 MPa**  
 Operating temperature: **5° ÷ 45° C**  
 Opening angle: **adjustable from 0° to 135°**  
 Arm position: **180°**  
 Electronic sensor with M12 swivel connector, from 0° to 90°  
 Supply voltage: **10 ÷ 30 Vdc**  
 IP code: **IP 65**

Subject to technical modifications without notice

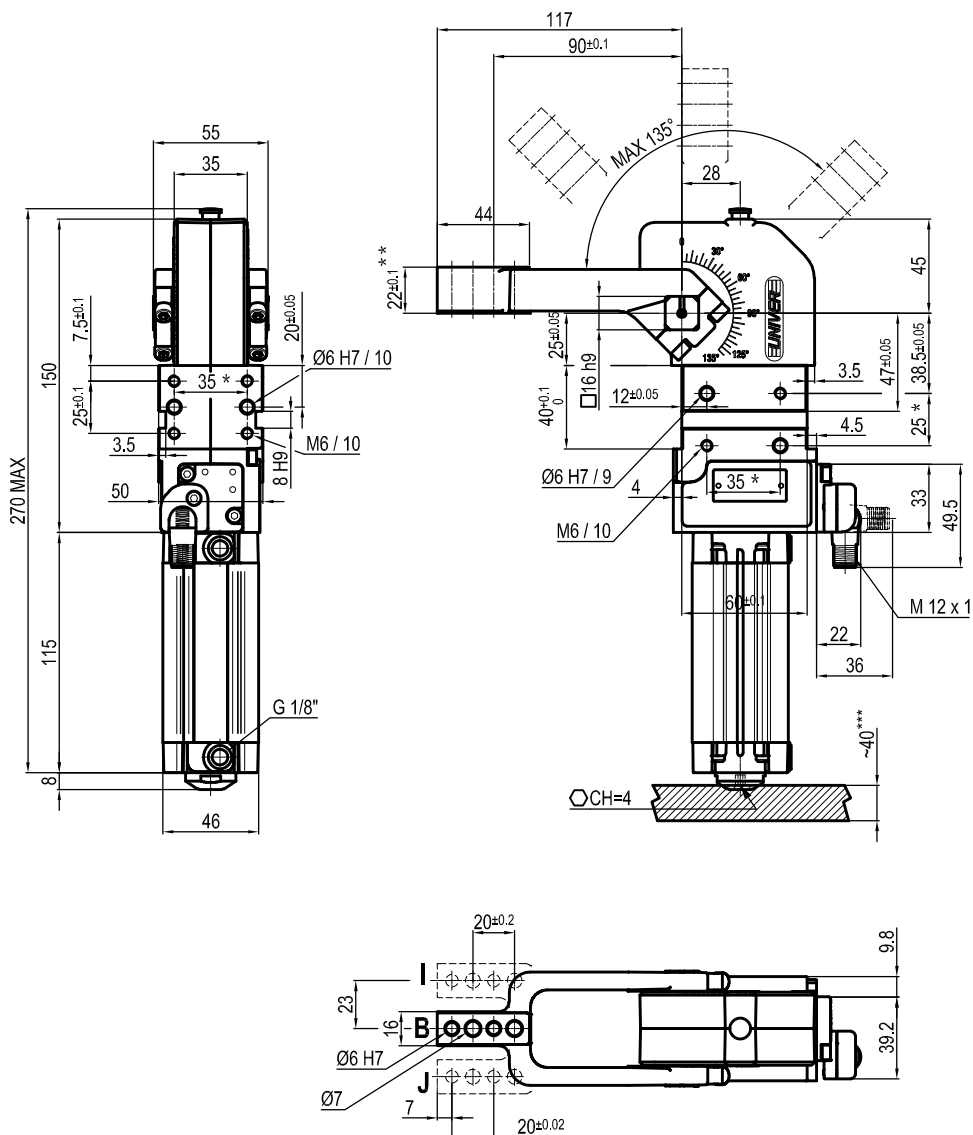

\* : TOLERANCE BETWEEN DOWELS  $\pm 0.02$ , BETWEEN SCREW HOLES  $\pm 0.1$

\*\* : TOLERANCE AT 80 mm FROM PIVOT POINT

\*\* : AREA TO ACCESS ANGLE ADJUSTMENT

**UABP40V \_\_ K0**
**6** ARM STYLE

**7** ARM TYPE

**6 7**

B = Central  
I = Right  
J = Left

A = Aluminium  
S = Steel

Size $\emptyset$	Cylinder bore $\emptyset$	Holding moment	Clamping moment (0,5 MPa)	Weight (clamping arm not included)
40 mm	32 mm	600 Nm	125 Nm	1,4 Kg

Min./Max. operating pressure: **0,4 / 0,6 MPa**

Operating temperature: **5°  $\div$  45° C**

Opening angle: **adjustable from 0° to 135°**

Arm position: **90°**

Electronic sensor with M12 swivel connector, from 0° to 90°

Supply voltage: **10  $\div$  30 Vdc**

IP code: **IP 65**

Subject to technical modifications without notice

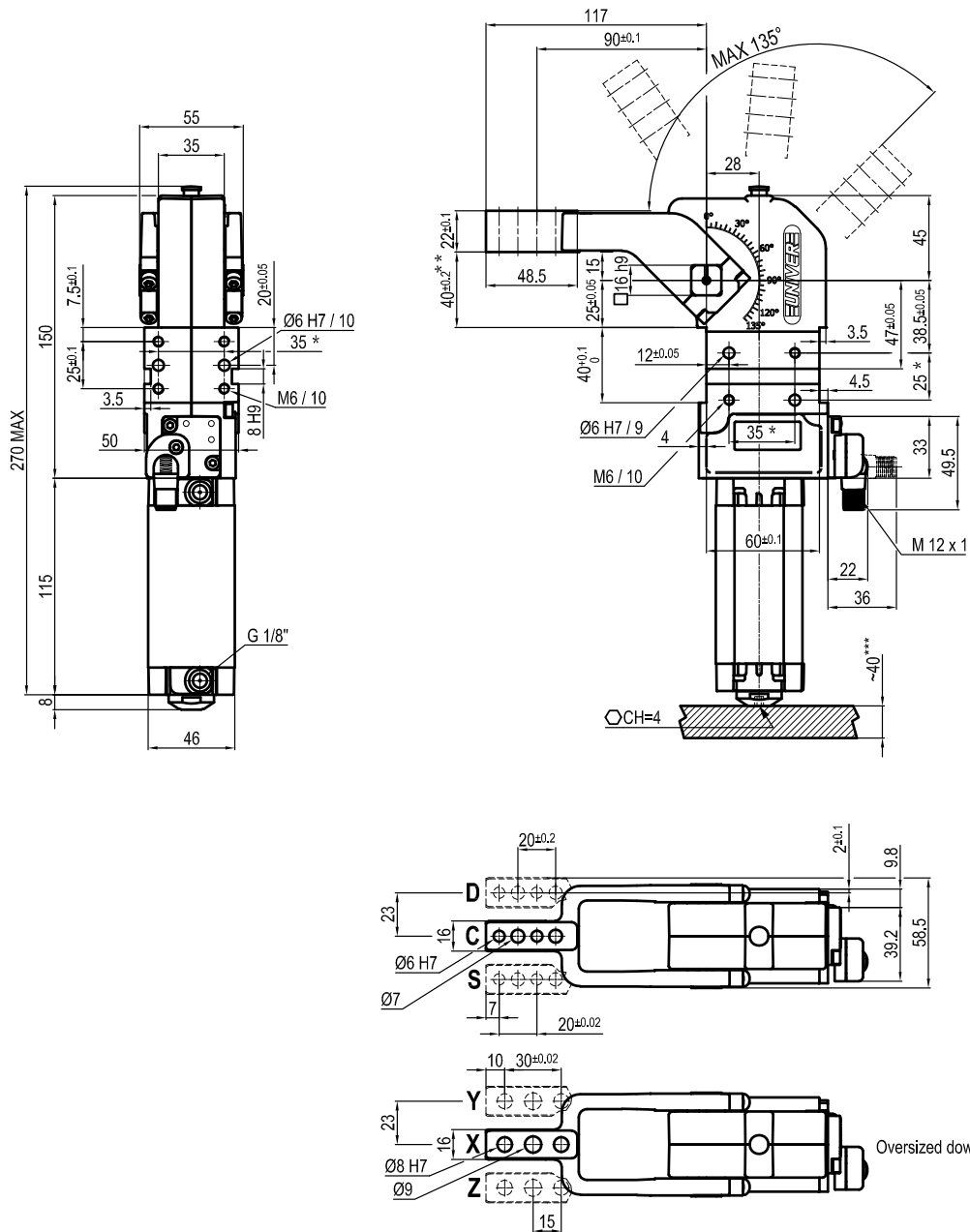

\* : TOLERANCE BETWEEN DOWELS  $\pm 0.02$ , BETWEEN SCREW HOLES  $\pm 0.1$

\*\* : TOLERANCE AT 80 mm FROM PIVOT POINT

\*\*\*: AREA TO ACCESS ANGLE ADJUSTMENT

**UABP40V \_\_ K0**
**6** ARM STYLE

**7** ARM TYPE

**6 7**

C = Central  
D = Right  
S = Left

A = Aluminium  
S = Steel

Size $\varnothing$	Cylinder bore $\varnothing$	Holding moment	Clamping moment (0,5 MPa)	Weight (clamping arm not included)
40 mm	32 mm	600 Nm	125 Nm	1,4 Kg

Min./Max. operating pressure: **0,4 / 0,6 MPa**

Operating temperature: **5° ÷ 45° C**

Opening angle: **adjustable from 0° to 135°**

Arm position: **90°**

Electronic sensor with M12 swivel connector, from 0° to 90°

Supply voltage: **10 ÷ 30 Vdc**

IP code: **IP 65**

Subject to technical modifications without notice

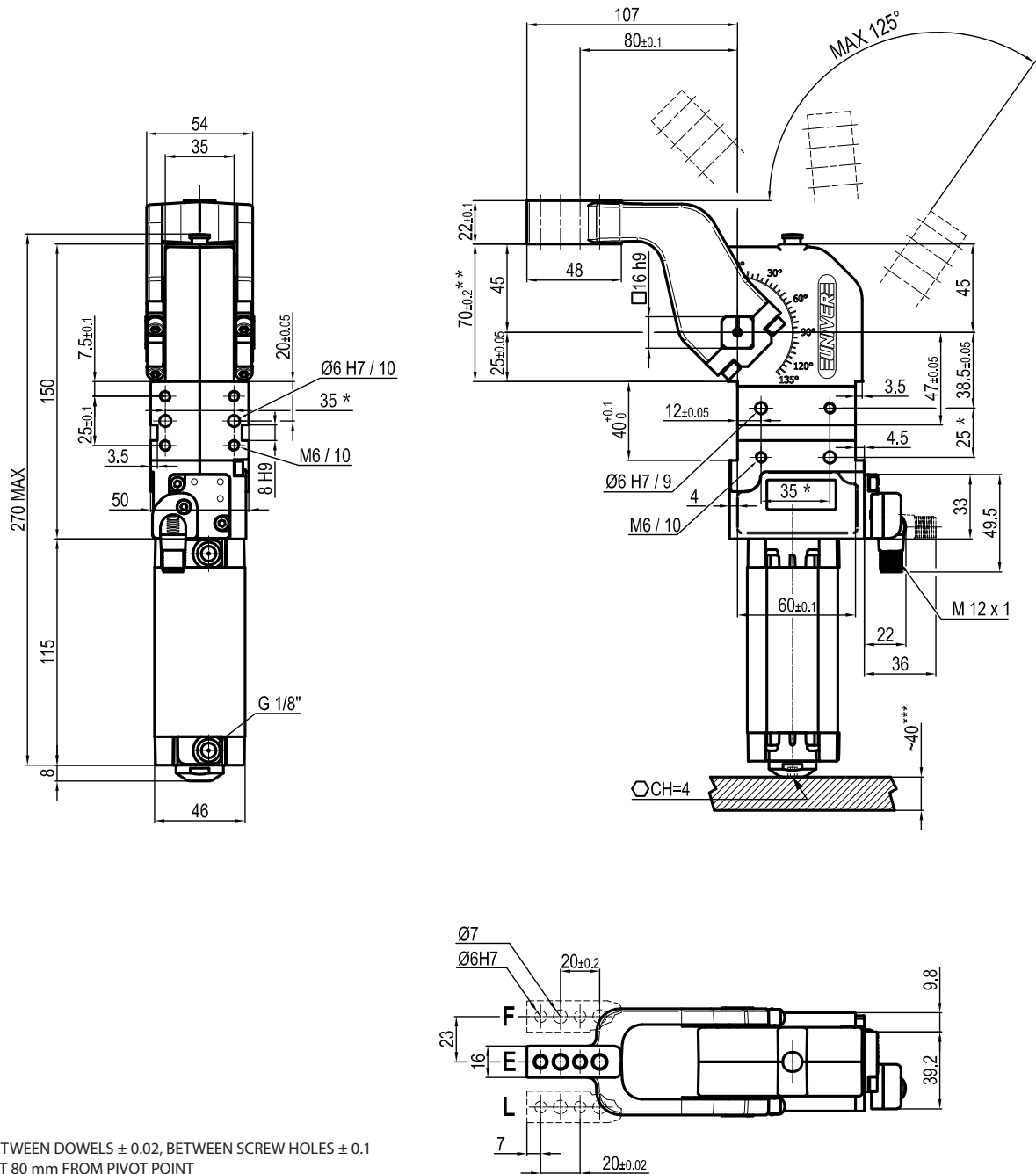

\* : TOLERANCE BETWEEN DOWELS ± 0.02, BETWEEN SCREW HOLES ± 0.1  
 \*\* : TOLERANCE AT 80 mm FROM PIVOT POINT  
 \*\*\* : AREA TO ACCESS ANGLE ADJUSTMENT

**UABP40V \_\_ K0**
**6 ARM STYLE**
**7 ARM TYPE**
**6 7**

E = Central  
 F = Right  
 L = Left

A = Aluminium  
 S = Steel

Size Ø	Cylinder bore Ø	Holding moment	Clamping moment (0,5 MPa)	Weight (clamping arm not included)
40 mm	32 mm	600 Nm	125 Nm	1,4 Kg

 Min./Max. operating pressure: **0,4 / 0,6 MPa**

 Operating temperature: **5° ÷ 45° C**

 Opening angle: **adjustable from 0° to 125°**

 Arm position: **90°**

Electronic sensor with M12 swivel connector, from 0° to 90°

 Supply voltage: **10 ÷ 30 Vdc**

 IP code: **IP 65**

Subject to technical modifications without notice