

Economical, compact, needs-based: Quality for your standard processes

P42 Pressure sensor with IO-Link

This temperature compensated transmitter is ideal for sanitary pressure monitoring in a variety of applications in breweries, dairies, and the beverage industry.

New: Digital communication of measurement data via IO-Link.

Benefits with P42 in Process control

Now you can also rely on the renowned Anderson-Negele quality for applications with standard process requirements. The P42 is a fast, precise, and economical device that measures process pressures and transmits the data digitally in high accuracy and speed via IO-Link.

Advantages of the P42:

- **Compact stainless-steel design** with direct output to the PLC
- **Precise measurement even at high pressures** up to 40 bar, overpressure resistance up to 105 bar
- **Very robust and durable design** despite its delicate appearance
- **Absolute or relative pressure measurement.**
- **Relative measurement without or with vacuum range (Compound)**
- **Individual, needs-based adaptation** of the measuring range to the respective process

Benefits with P42 in Level control

With an extensive product portfolio, Anderson-Negele sensors cover all requirements of high-precision level measurement for a wide range of applications.

P42 expands the application variety with the digital interface IO-Link and enables a fast, precise, and economic function for standard requirements.

Advantages of the P42:

- **Precise measurement** due to a pressure range that can be finely tuned and narrowly defined
- **Optional compound measurement:** Accurate relative pressure determination including vacuum range

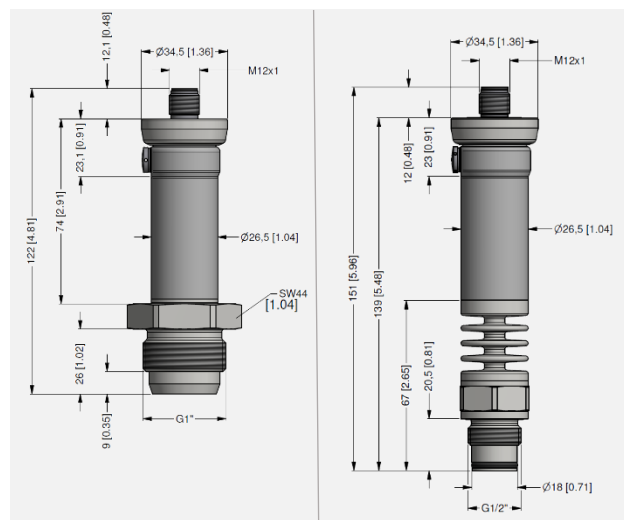

Technical specifications at a glance

- **Digital data transmission with IO-Link**
- Process temperature up to 125 °C (257 °F), CIP/SIP cleaning up to 150 °C (302 °F) / max. 60 min
- With optional spacer the temperature range is up to 300 °C (572 °F) permanent
- Compact design without display, sensor completely made of stainless steel
- Process connection: hygienic thread G1" (CLEANadapt), thread G1/2", Tri-Clamp 1", 1,5" and 2", Varivent DN25 and DN40/50
- Vacuum proof

Digital Communication with IO-Link

The digital interface IO-Link enables bidirectional communication and, thus, status control and preventive maintenance at any time to avoid production downtimes. Plug and Play technology saves time and money for installation and commissioning, and automatic detection, configuration and parameterization make sensor replacement easier than ever before.

Order Code									
P42	Pressure sensor								
	Measuring range of pressure cell								
	1	0.2 bar (3 psi)							
	2	0.4 bar (6 psi)							
	3	1.0 bar (15 psi)							
	4	2.0 bar (30 psi)							
	5	4.0 bar (60 psi)							
	6	7.0 bar (100 psi)							
	7	10 bar (145 psi)							
	8	20 bar (290 psi)							
	9	40 bar (580 psi)							
		Pressure measurement							
		A Absolute (absolute measurement, min. 0.4 bar (6 psi))							
		G Gauge (relative measurement without vacuum)							
		C Compound (relative measurement including vacuum)							
		Process connection							
		195 G1/2" DIN3852 (front flush with O-ring) only for measurement range ≥ 1 bar (15 psi)							
		182 CLEANadapt G1" hygienic							
		003 Tri-Clamp 1" / 1½"							
		005 Tri-Clamp 2"							
		V25 Varivent type F, DN25 (adaption by means of CLEANadapt)							
		V40 Varivent type N, DN40/50 (adaption by means of CLEANadapt)							
		Sealing material (only selectable for process connections 195)							
		X No seal							
		A EPDM < 125 °C (257 °F)							
		B FKM < 200 °C (392 °F)							
		C FFKM > 200 °C (392 °F)							
		Capillary fill							
		6 FDA approved oil							
		Sensor version process temperature							
		X Standard temperature (max. 125 °C (257 °F))							
		H High temperature version (max. 300 °C (572 °F))							
		Physical unit							
		B bar							
		P psi							
		Material certificate							
		X No certificate							
		Z 3.1 Material certificate							
		Configuration							
		0 Fixed value							
P42	1	A	182	X	6	X	B	X	0