

Series 4L

Piezoresistive OEM pressure transducer in a highly compact design

Features

- Ideal for OEM applications with limited installation space
- Robust stainless-steel housing
- Front-flush, gap-free welded diaphragm
- Very high proof pressure
- Optimised thermal behaviour

Technology

- Insulated piezoresistive pressure sensor encapsulated in an oil-filled metal housing
- Ideal for mounting with O-ring
- Typical range of output signal of 160 mV / mA

Typical applications

- OEM
- Industry
- Dive depth measurement
- Handheld devices



Accuracy

± 0,50 %FS

Long-term stability

± 0,50 %FS / year

Pressure ranges

0...10 bar to 0...200 bar

Series 4L

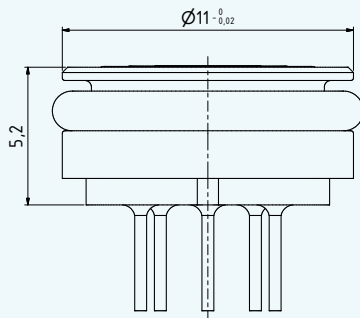
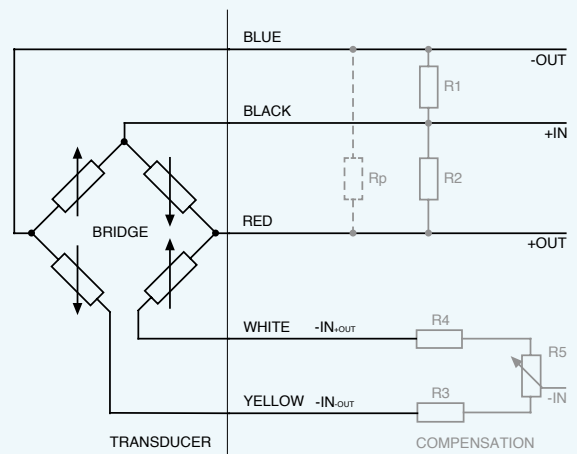

Diagram of a measurement bridge with compensation



Series 4L – Specifications

Standard pressure ranges

Absolute pressure PAA	Absolute pressure PA	Proof pressure	Sensitivity		
			min.	type	max.
0...10	0...10	30	12	16	20
0...20	0...20	60	6	8	10
0...30	0...30	90	4	5,3	6,7
0...50	0...50	150	2,4	3,2	4
0...100	0...100	300	1,2	1,6	2
0...160	0...160		0,75	1,0	1,25
0...200	0...200				
bar abs.	bar	bar	mV / (mA × bar)		
Reference pressure at 0 bar abs. (vacuum)	Reference pressure at 1 bar abs.	Based on reference pressure			

Performance

Accuracy @ RT (20...25 °C)	± 0,50 %FS max.	Non-linearity (best fit straight line, BFSL), pressure hysteresis, non-repeatability
Offset @ RT (20...25 °C)	< ± 25 mV / mA	Uncompensated, the sensitivity value must be added for PA
	< ± 2 mV / mA	Compensated with R3 or R4
Compensated temperature range	0...50°C	
Long-term stability	≤ ± 0,50 %FS	Per year under reference conditions
Position dependency	≤ 2 mbar	Calibrated in vertical installation position with metal diaphragm facing downwards
Temperature coefficient (TC)	≤ ± 0,025 %FS / K	Zero (TCzero) pre-compensated with R1 or R2
	≤ ± 0,06 % / K	Sensitivity (TCsens)
	1800...3000 ppm / K	Total bridge resistance (TCres)

Electrical data

Half-open measurement bridge

Constant current supply	1 mA nominal 3 mA maximum	
Bridge resistance @ RT (20...25 °C)	3,5 kΩ ± 20 %	
Electrical connection	Gold-plated pins ø 0,45 mm L = 4 mm ± 0,5 mm	Optional: Silicone wires AWG28, L = 70 mm, other lengths on request
Insulation	> 100 MΩ @ 500 VDC	

Series 4L – Specifications

Mechanical data

Materials in contact with media

Housing and separating diaphragm	Stainless steel AISI 316L	
O-ring	FKM (75 Shore) ø 8 mm x 1,5 mm -20...200 °C	Optional: Others on request

Other materials

Pressure transducer oil filling	Silicone oil	Optional: Others on request
---------------------------------	--------------	-----------------------------

Further details

Diameter x height	ø 11 mm x 5,2 mm	See dimensions and options
Weight	approx. 2 g	

Environmental conditions

Medium temperature range	-20...85 °C	Icing not permitted
Ambient temperature range	-20...85 °C	
Storage temperature range	-20...85 °C	
Vibration resistance	10 g, 10...2000 Hz, ± 10 mm	IEC 60068-2-6
Shock resistance	50 g, 6 ms	IEC 60068-2-27
Natural frequency (resonance)	> 30 kHz	
Pressure endurance @ RT (20...25 °C)	> 10 million pressure cycles	0...100 %FS
Dead volume change @ RT (20...25 °C)	< 2 mm ³	

Series 4L – Dimensions and options

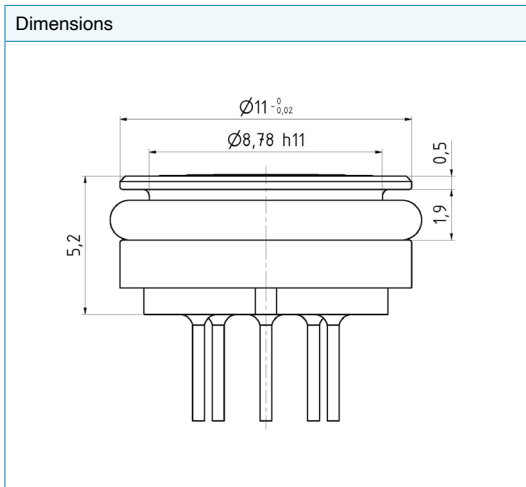

Electrical connection

Glass feedthrough connection		Half-open measurement bridge pin assignment			
		PIN	Label	Designation	Wire colour
		1	+OUT	Pos. Output	red
		2	+IN	Pos. Supply	black
		3	-OUT	Neg. Output	blue
		4	-IN _{OUT}	Neg. Supply (half bridge -OUT)	yellow
	5	-IN _{+OUT}	Neg. Supply (half bridge +OUT)	white	

Overview of customer-specific options

- Calibration to customer-specific pressure ranges
- Calibration to customer-specific temperature ranges
- Electrical connection via silicone wires
- O-rings made of other materials
- Other oil filling types for pressure transducers: e.g. special oils for oxygen applications
- Modifications to customer-specific applications

Examples of related products

- Series 4LC: With integrated signal conditioner and analogue ratiometric output signal 0,5...4,5 V
- Series 4LD: With integrated signal conditioner and I2C interface
- Series 7L, 9L and 10L: larger designs for extended pressure and temperature ranges

Series 4L – Analysis and characteristic lines

Standard analysis

The pressure transducers are intended for O-ring mounting and are therefore designed for low transmission of forces. This installation enables the values measured in the test equipment to remain unchanged. If the transducers are not de-energised when they are installed, the mechanical forces may change the measured values and the stability of the pressure transducers.

Calibration sheet: Example type PA-10L					Key
----- 449					<ol style="list-style-type: none"> Type (PA-10L) and measuring range (10 bar) of pressure sensor Serial number of pressure sensor Actual test temperatures Uncompensated zero offset Zero offset values with calculated compensation resistor R1 (+) or R2 (-) Zero offset values with calculated compensation resistors R1 or R2 and R3 or R4 Temperature zero error with calculated compensation resistors Calculated compensation resistor values R1 or R2 (TCzero) and R3 or R4 (offset) RB: Bridge resistance at room temperature Calculated offset with compensation resistors R1 or R2 and R3 or R4 Sensitivity of pressure sensor at room temperature 25°C Pressure test points Signal change at pressure test points at room temperature 25°C Nonlinearity (best straight line through zero) Nonlinearity (best straight line) Result of the long-term stability test Lot number and identification of silicon wafer Insulation test Excitation (constant current) Date of test ----- Test equipment
PA-10L / 10 bar / 10-1005-118 ⁽¹⁾ Sn I107547 ⁽²⁾					
----- 29/01					
⁽³⁾ Temp	⁽⁴⁾ Zero	⁽⁵⁾ +510	⁽⁶⁾ Comp	⁽⁷⁾ dZero	
[°C]	[mV]	[mV]	[mV]	[mV]	
-9.5	18.5	13.3	-0.6	0.2	
0.1	18.7	13.3	-0.6	0.2	
25.0	19.1	13.1	-0.8	0.0	
50.2	19.8	13.0	-0.9	-0.1	
79.9	20.8	12.9	-1.1	-0.2	
----- L1					
COMP	R1	510 kOhm ⁽⁸⁾	R3	56.0 Ohm ⁽⁸⁾	
RB	3482 Ohm ⁽⁹⁾				
ZERO	-0.8 mV ⁽¹⁰⁾		P_atm	964 bar	
SENS	16.41 mV/bar ⁽¹¹⁾				
LIN			⁽¹⁴⁾ Lnorm	⁽¹⁵⁾ Lbfl	
⁽¹²⁾ [bar]	⁽¹³⁾ [mV]	[%Fs]		[%Fs]	
0.000	0.0	0.00		-0.01	
2.500	41.1	0.02		0.01	
5.000	82.1	0.00		0.00	
7.500	123.1	-0.02		-0.01	
10.000	164.1	-0.01		-0.01	

Long Term Stability Ok ⁽¹⁶⁾					
Lot 72114-2 ⁽¹⁷⁾					
Test 500 Volt Ok ⁽¹⁸⁾					
Supply 1.000 mA ⁽¹⁹⁾					
01.09.17 ⁽²⁰⁾ ----- GOL3.A03DIK ⁽²⁰⁾					

Notes

- The indicated specifications apply only for constant current supply of 1 mA. The sensor must not be supplied with more than 3 mA. The output voltage is proportional to the supply current. If the supply deviates from the calibration, this will cause signal shifts.
- The compensation resistors described in this data sheet are not part of the pressure transducer and are not included in the scope of delivery.
- It is recommended to use compensation resistors with temperature coefficients of < 50 ppm / °C for large temperature ranges. Sensor and resistors can be exposed to different temperatures.
- Fine adjustment of zero with R5 potentiometer (20 Ω) is possible. In addition, a maximum TC-sensitivity can be guaranteed on request or the value for the compensation resistor (Rp) can be indicated. See Diagram "Measurement bridge with compensation" on page 1.

Characteristic lines

Examples of typical characteristic lines of the temperature coefficients, normalised at 25 °C, uncompensated and compensated

