

DXRE*J

DIRECTIONAL CONTROL VALVES, PILOT OPERATED, WITH OBE AND FEEDBACK SERIES 31

SUBPLATE MOUNTING

DXRE5RJ	ISO 4401-05
DXRE7J	ISO 4401-07
DXRE8J	ISO 4401-08
DXRE10J	ISO 4401-10
DXRE11J	ISO 4401-10 oversized ports

OPERATING PRINCIPLE

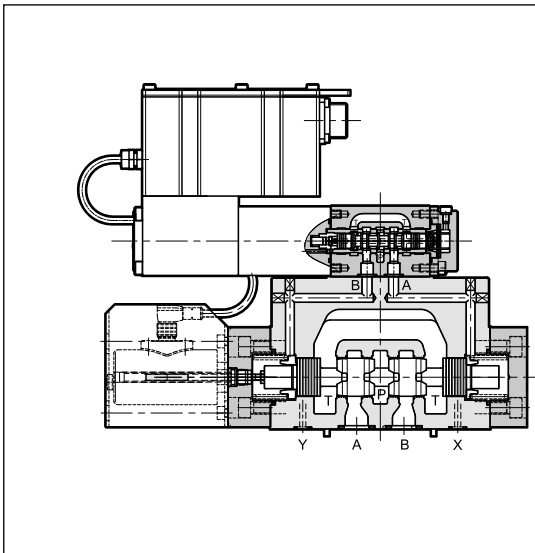

- DXRE*J are directional control valves operated by a servo-proportional pilot, with mounting surface compliant with ISO 4401 standards. The main spool position is controlled by a linear transducer LVDT in closed loop, which ensures high precision and repeatability. .
- The valve is featured by integral electronic based on SMD technology which ensures standard regulations and simplifies the electric wiring. The unit doesn't require any adjustment other than the possible electronic regulation of the zero.
- Two types of integrated electronics are available, with analogue or fieldbus interfaces.
- Suitable for control applications with closed loop of position, velocity and pressure. With a power down or without the enable input, the main spool is set to a fail-safe position by springs.

HYDRAULIC SYMBOL (typical)

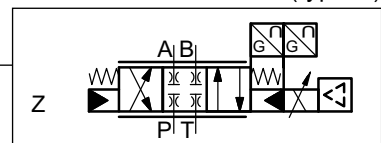

PERFORMANCES

(obtained with mineral oil with viscosity of 36 cSt at 50°C and p =140 bar)

		DXRE5RJ	DXRE7J	DXRE8J	DXRE10J	DXRE11J
Max operating pressure: P - A - B ports T - X - Y ports	bar	350 250				
Controlled flow with Δp 10 bar P-T	l/min	100	220	400	800	1000
Hysteresis	% Q _{max}	< 0.2%				
Repeatability	% Q _{max}	± 0.1%				
Electrical characteristics		see paragraph 4				
Ambient temperature range	°C	-20 / +60				
Fluid temperature range	°C	-20 / +80				
Fluid viscosity range	cSt	10 + 400				
Fluid contamination degree		According to ISO 4406:1999 class 18/16/13 (16/14/11 for longer life)				
Recommended viscosity	cSt	25				
Mass	kg	8	10.2	17	56	56

1 - IDENTIFICATION CODE

1.1 - Standard electronics

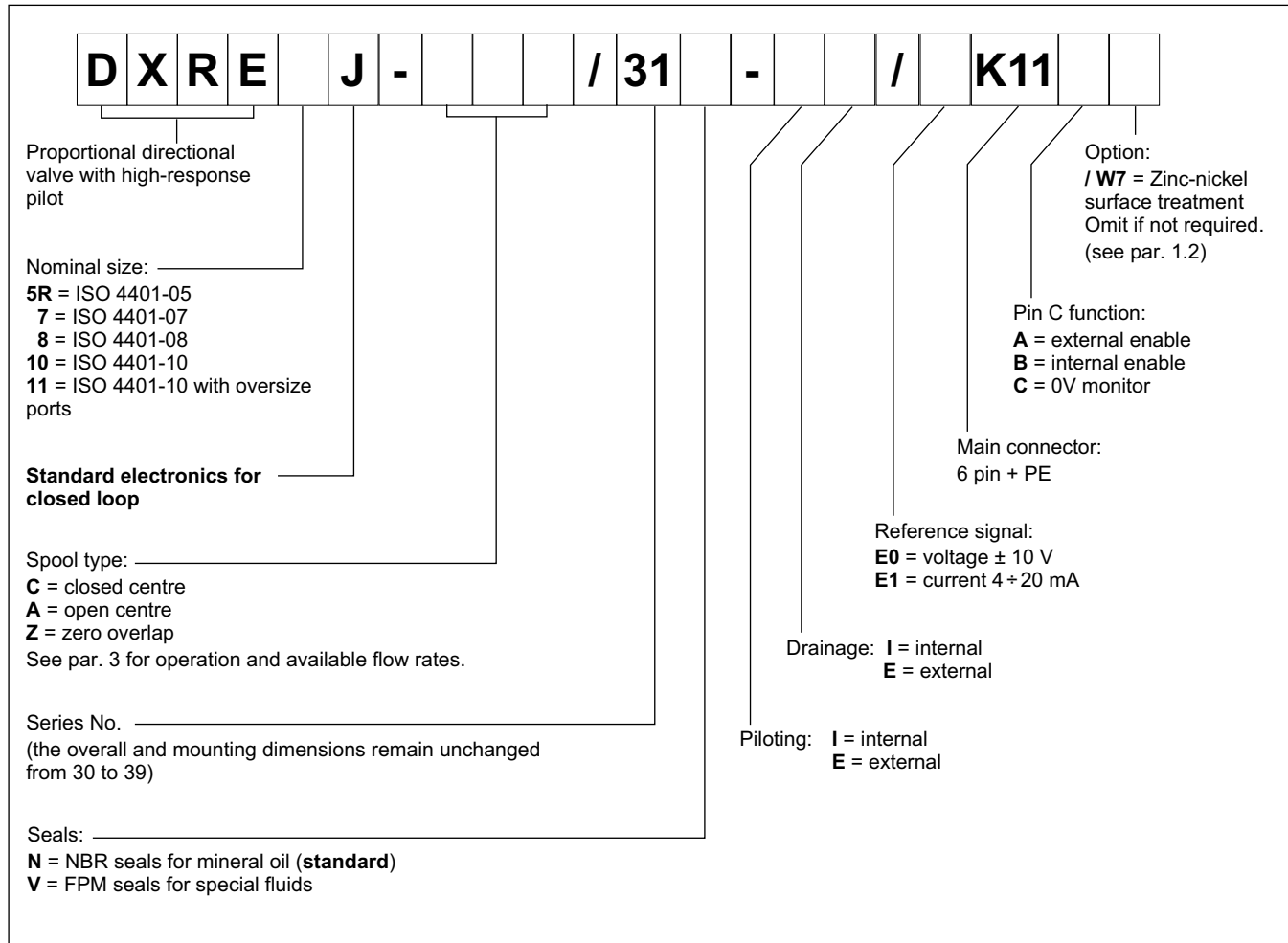

1.2 - Surface treatments

The standard valve is supplied with surface treatment of phosphating black.

The zinc-nickel finishing makes the valve suitable to ensure a salt spray resistance up to **600** hours (test operated according to UNI EN ISO 9227 standards and test evaluation operated according to UNI EN ISO 10289 standards).

1.3 - Electronics with fieldbus communication

D	X	R	E	JH	-	/	31	-	-	K16	/								
----------	----------	----------	----------	-----------	---	---	-----------	---	---	------------	---	--	--	--	--	--	--	--	--

Proportional directional valve with high-response pilot

Nominal size: _____
5R = ISO 4401-05
7 = ISO 4401-07
8 = ISO 4401-08
10 = ISO 4401-10
11 = ISO 4401-10 with oversize ports

Digital integrated electronics for closed loop with fieldbus communication

Spool type: _____
C = closed centre
A = open centre
Z = zero overlap
 See par. 2 for operation and available flow rates.

Series No. _____
 (from 30 to 39 sizes and mounting dimensions remain unchanged)

Seals: _____
N = NBR seals for mineral oil (**standard**)
V = FPM seals for special fluids

Drainage: _____
I = internal
E = external

Piloting: _____
I = internal
E = external

Option:
/ W7 = Zinc-nickel surface treatment
 Omit if not required.
 (see par. 1.2)

X4 Analogue transducer:
0 = none
1 = version 1
 (single /double transducer)

X7 Digital transducer:
0 = none
1 = version 1 (SSI type)
2 = version 2 (Encoder type)

X2, X3 Fieldbus type:
CA = CAN Open
PD = PROFIBUS DP
EC = EtherCAT
EN = Ethernet /IP
PN = Profinet
PL = PowerLink

X1 Main connection configuration:
D1 = one command
D0 = full digital version (on request - available for reference signal FD type only)

Main connection 11 pin + PE

Reference signal:
E0 = voltage ±10V
E1 = current 4 + 20mA
FD = full digital version (on request)

2 - COMPARISON AMONG INTEGRATED ELECTRONICS

J type

102

JH type

116

dimensions in mm

1	Connection 6 pin + PE
X1	Main connection 11 pin + PE
X2	Fieldbus communication (IN)
X3	Fieldbus communication (OUT)
X4	Connection for analogue transducer
X7	Connection for digital transducer

NOTE 1: Depending on the chosen version, X4 and X7 connections may not be present. Please refer to sections 5, 6 and 7 for connections descriptions and pinouts.

NOTE 2: Related mating connectors have to be ordered separately. See catalogue 89 000.

3 - AVAILABLE CONFIGURATIONS

The valve configuration depends on the combination of spool type and rated flow.

3 positions with spring centering

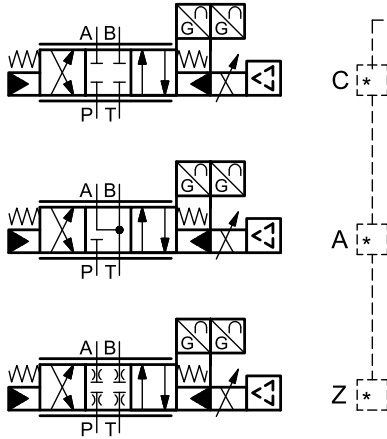

valve type	*	Controlled flow with Δp 10 bar P-T
DXRE5RJ	100	100 l/min
DXRE7J	120	120 l/min
	220	220 l/min
DXRE8J	250	250 l/min
	400	400 l/min
DXRE10J	800	800 l/min
DXRE11J	1000	1000 l/min

OFFSET POSITION for Z SPOOLS

After electrical switch-off or Enable signal switch-off (version K11A) the main spool moves to springs offset position, with limited opening (1%... 6% of main spool stroke in direction P-B / A-T)

detailed symbol (spool Z)

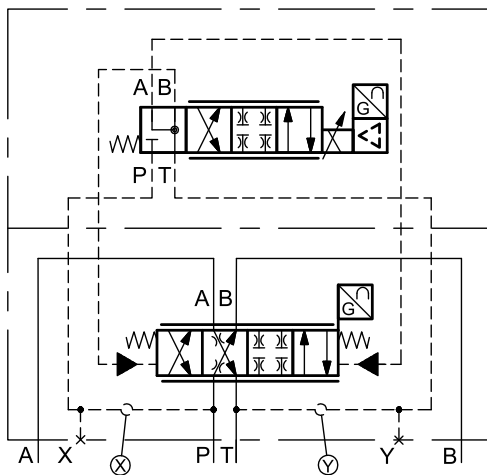

4 - ELECTRONICS COMMON DATA

Duty cycle		100% (continuous operation)
Protection class according to EN 60529		IP65 / IP67
Supply voltage	V DC	24 (from 19 to 30 VDC), ripple max 3 Vpp
Power consumption	VA	35
Maximum solenoid current	A	2.6
Fuse protection, external	A	(fast), max current 4A
Managed breakdowns		Overload and electronics overheating, LVDT sensor error, cable breakdown, supply voltage failures
Electromagnetic compatibility (EMC) emissions EN 61000-6-4, immunity EN 61000-6-2		According to 2014/30/EU standards

5 - DXRE*J - STANDARD ELECTRONICS

5.1 - Electrical characteristics

Command signal: voltage (E0) current (E1)	V DC mA	±10 (Impedance Ri = 11 kOhm) 4 ÷ 20 (Impedance Ri = 58 Ohm)
Monitor signal (current to solenoid): voltage (E0) current (E1)	V DC mA	±10 (Impedance Ro > 1 kOhm) 4 ÷ 20 (Impedance Ro = 500 Ohm)
Communication for diagnostic		LIN-bus Interface (by means of the optional kit)
Connection		6 pin + PE (MIL-C-5015-G - DIN EN 175201-804)

5.2 - On-board electronics diagrams

VERSION A - External Enable

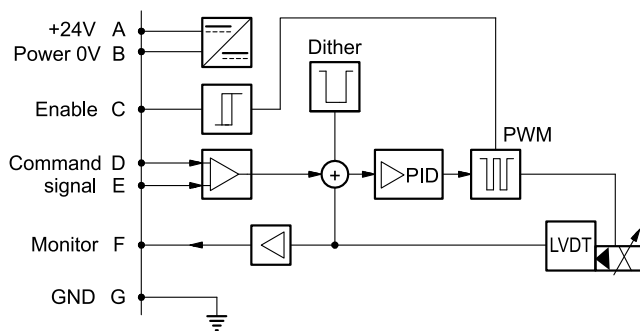

VERSION B - Internal Enable

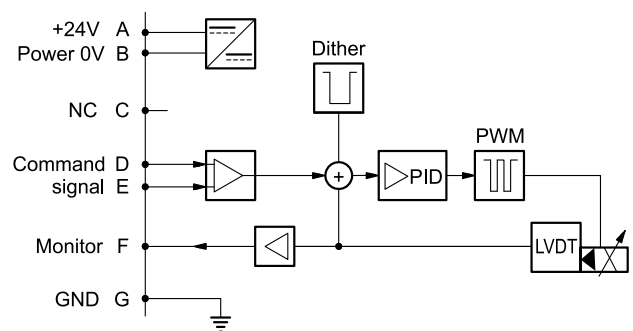

VERSION C - 0V Monitor

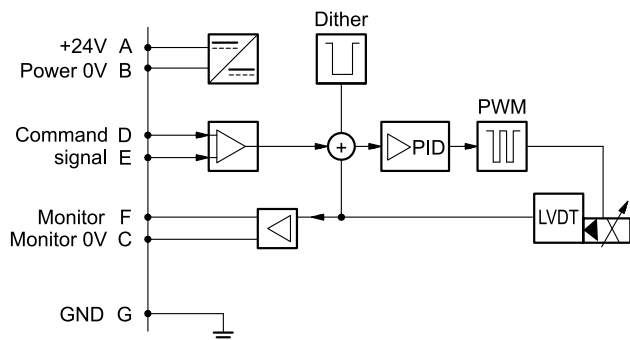

5.3 - Version with voltage command (E0)

The reference signal must be between -10V and +10V. The monitor feature of versions B and C becomes available with a delay of 0.5 sec from the power-on of the card.

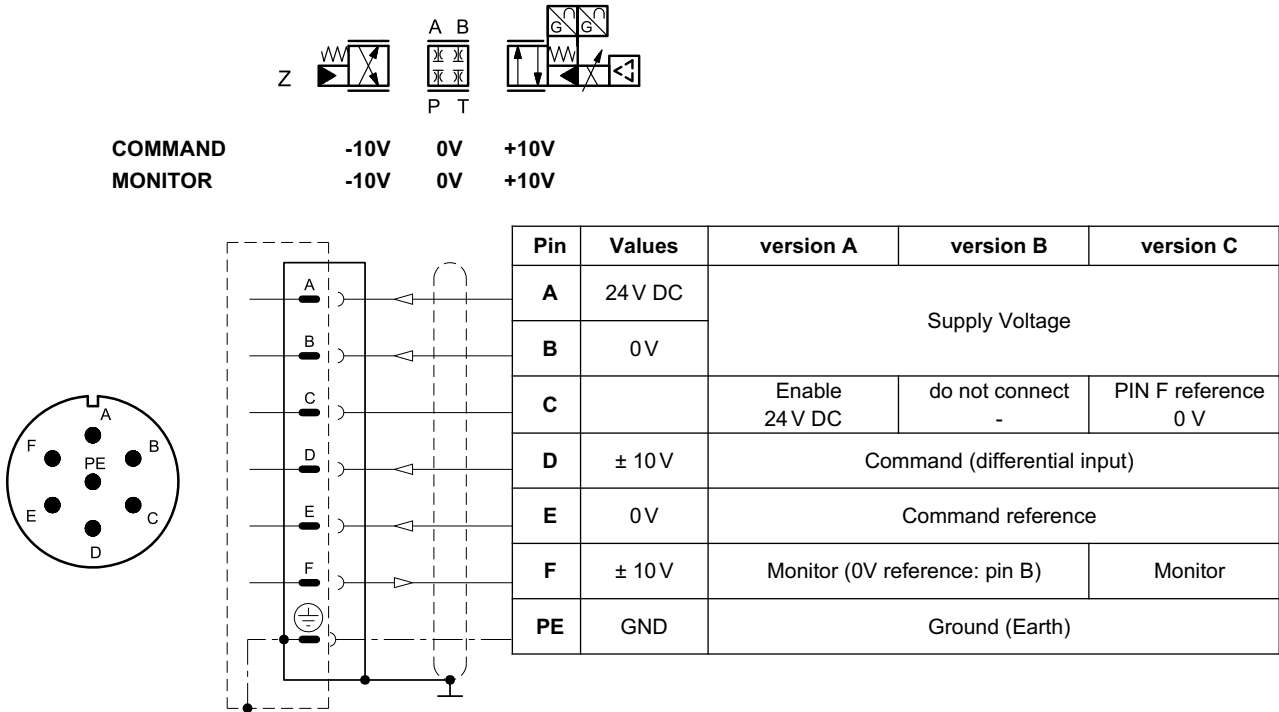

5.4 - Version with current command (E1)

The reference signal is supplied in current $4 + 20$ mA. If the current for command is lower than 4 mA the card shows a breakdown cable error. To reset the error is sufficient to restore the signal.

The monitor feature of versions B and C becomes available with a delay of 0.5 sec from the power-on of the card.

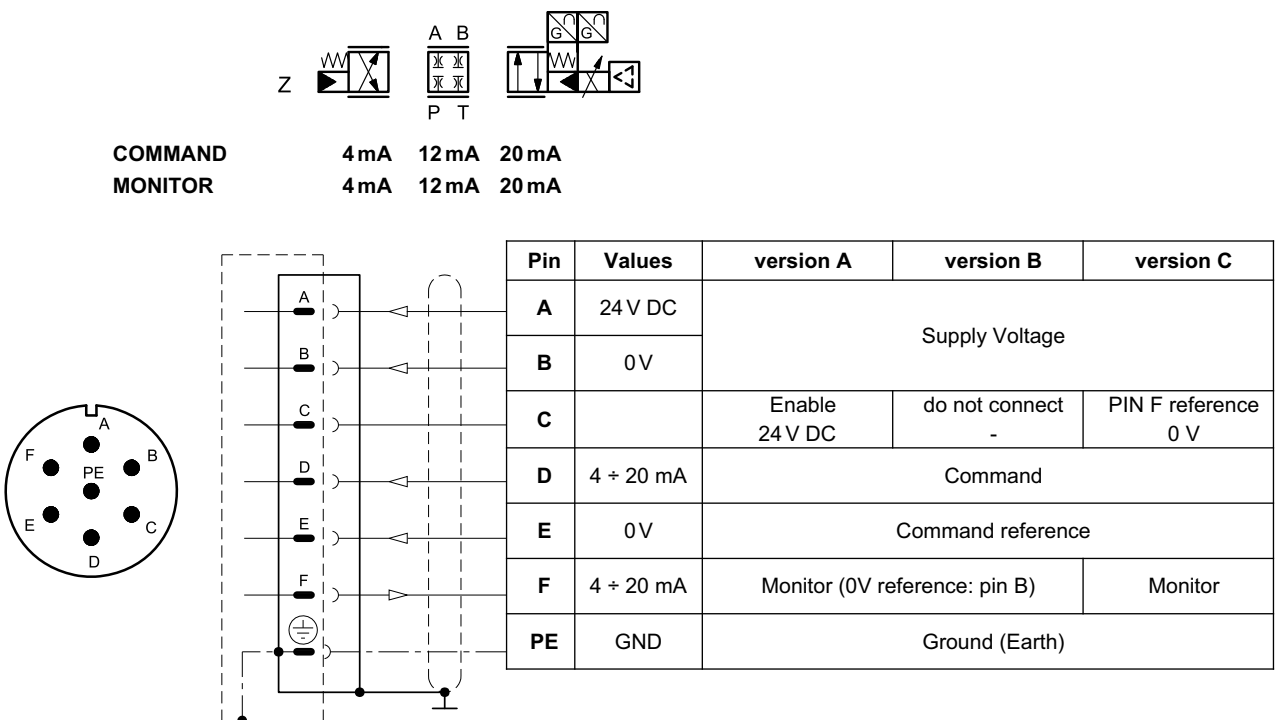

6 - DXRE*JH - FIELD BUS ELECTRONICS

The 11+ PE pin connection allows separate supply voltage for electronics and solenoids.

Command - valve position schemes as for the standard electronics. Please refer to pictures in par. 5.3 and 5.4.

6.1 - Electrical characteristics

Command signal: voltage (E0) current (E1) digital (FD)	V DC mA	± 10 (Impedance $R_i = 11 \text{ k}\Omega$) $4 \div 20$ (Impedance $R_i = 58 \text{ }\Omega$) via fieldbus
Monitor signal (current to solenoid): voltage (E0) current (E1)	V DC mA	± 10 (Impedance $R_o > 1 \text{ k}\Omega$) $4 \div 20$ (Impedance $R_o = 500 \text{ }\Omega$)
Communication / diagnostic		via Bus register
Communication interface standards CAN Open PROFIBUS DP EtherCAT, Ethernet /IP, Profinet, PowerLink		EN 50325-4+DS408 EN 50170-2 / IEC 61158 IEC 61158
Communication physical layer CAN Open PROFIBUS DP EtherCAT, Ethernet /IP, Profinet, PowerLink		optical insulated CAN ISO 11898 optical insulated RS485 fast ethernet, insulated 100 Base TX
Power connection		11 pin + PE (DIN 43651)

6.2 - X1 Main connection pin table

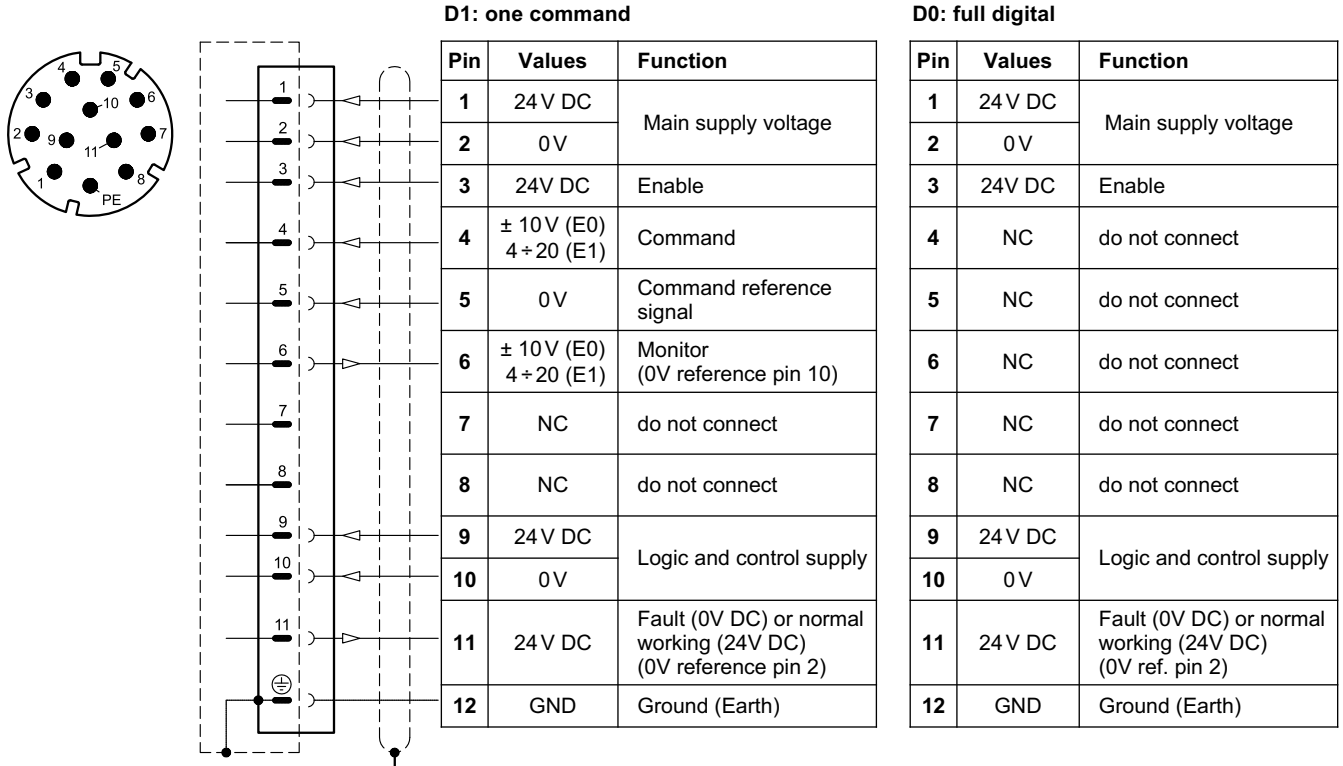

6.3 - FIELDBUS connections

Please wire following guidelines provided by the relative standards communication protocol.

6.3.1 - Communication connection CA (CAN Open)

X2 (IN) connection: M12 A 5 pin female



Pin	Values	Function
1	CAN_SH	Shield
2	NC	Do not connect
3	GND	Signal zero data line
4	CAN_H	Bus line (high)
5	CAN_L	Bus line (low)

X3 (OUT) connection: M12 A 5 pin male



Pin	Values	Function
1	CAN_SH	Shield
2	NC	Do not connect
3	GND	Signal zero data line
4	CAN_H	Bus line (high)
5	CAN_L	Bus line (low)

6.3.2 - Communication connection PD (PROFIBUS DP)

X2 (IN) connection: M12 B 5 pin male (IN)



Pin	Values	Function
1	+5 V	Termination supply signal
2	PB_A	Bus line (high)
3	0 V	Data line and termination signal 0
4	PB_B	Bus line (low)
5	SHIELD	

X3 (OUT) connection: M12 B 5 pin female



Pin	Values	Function
1	+5 V	Termination supply signal
2	PB_A	Bus line (high)
3	0 V	Data line and termination signal 0
4	PB_B	Bus line (low)
5	SHIELD	

6.3.3 - Communication connections: EC (EtherCat), EN (Ethernet/IP), PN (PROFINET), PL (POWERLINK)

X2 (IN) connection: M12 D 4 pin female



Pin	Values	Function
1	TX+	Transmitter
2	RX+	Receiver
3	TX-	Transmitter
4	RX-	Receiver
HOUSING	shield	

X3 (OUT) connection: M12 D 4 pin female



Pin	Values	Function
1	TX+	Transmitter
2	RX+	Receiver
3	TX-	Transmitter
4	RX-	Receiver
HOUSING	shield	

NOTE: Shield connection on connector housing is recommended.

6.4 - Digital transducer connection

X7 connection: M12 A 8 pin female

VERSION 1: SSI type

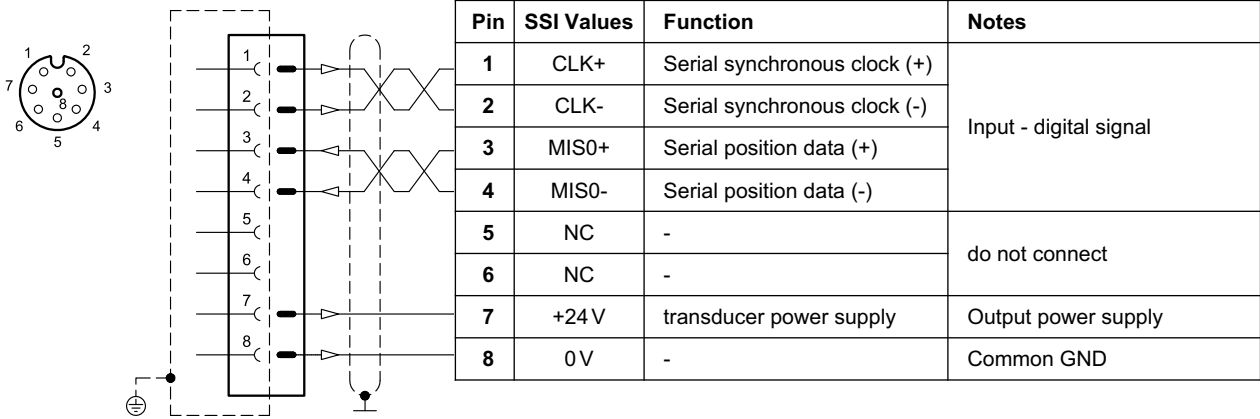

VERSION 2: ENCODER type

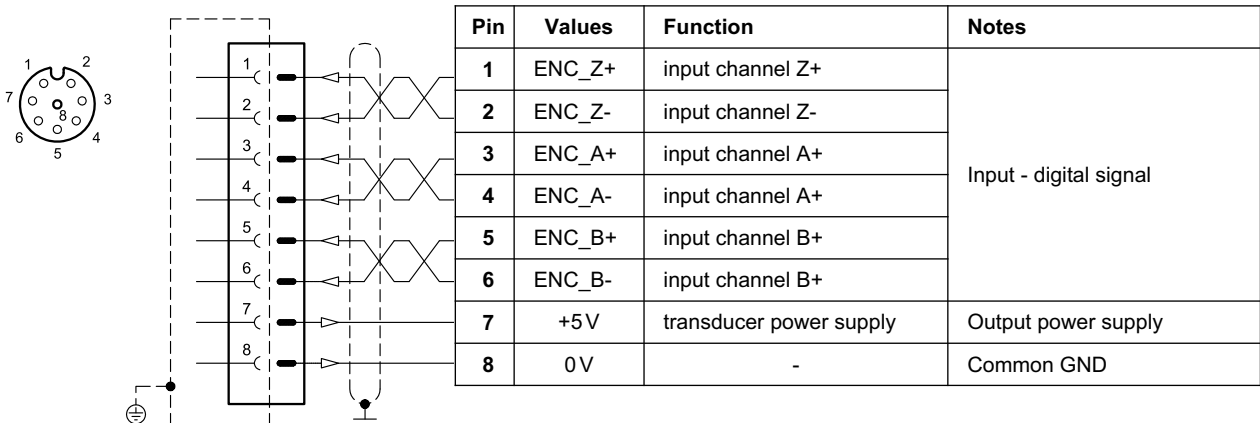

6.5 - Analogue transducer connection

X4 connection: M12 A 4 pin female

VERSION 1: single / double transducer

(single or double is a software-selectable option)

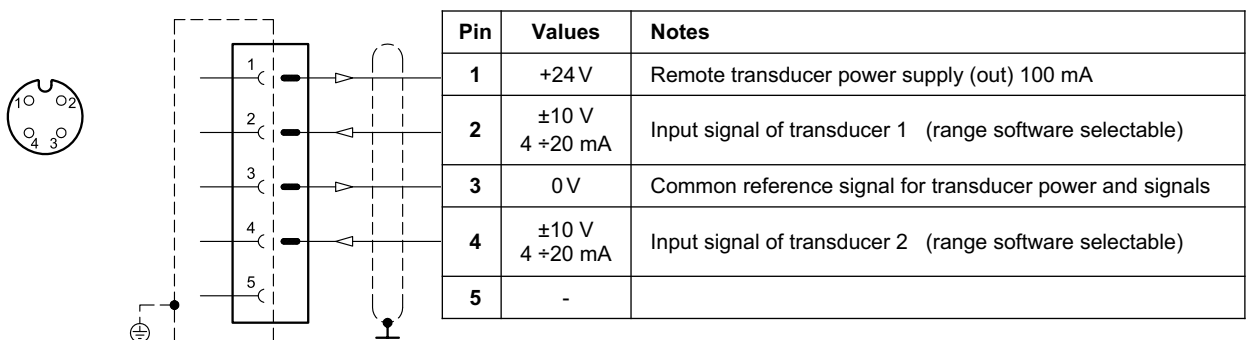

7 - CHARACTERISTIC CURVES

(with mineral oil with viscosity of 36 cSt at 50°C)

Typical flow rate curves at constant Δp related to the reference signal and measured for the available spools. The Δp values are measured per land.

7.1 - Characteristic curves DXRE5RJ

SPOOL C100 / A100

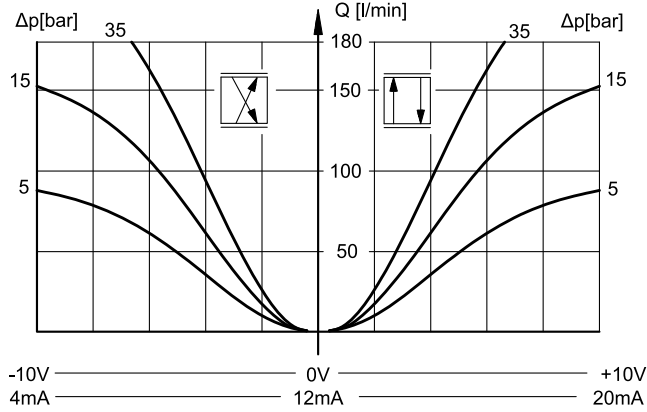

SPOOL Z100

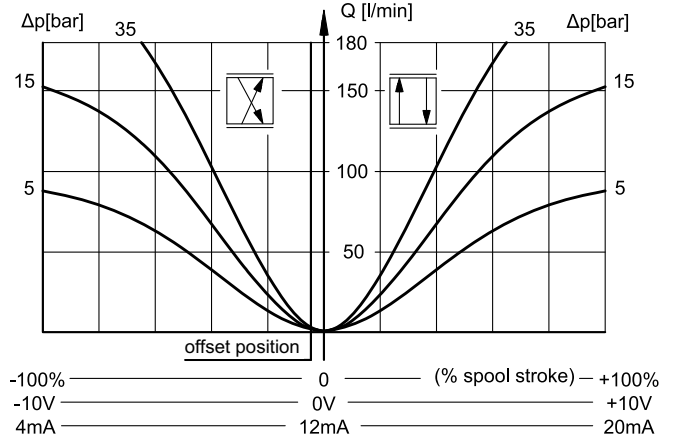

7.2 - Characteristic curves DXRE7J

SPOOL C120 / A120

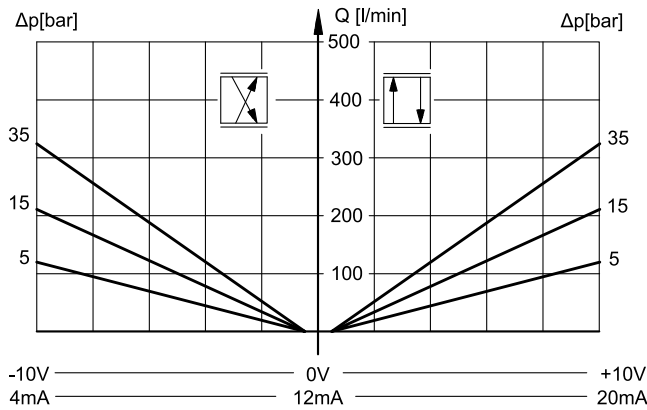

SPOOL C220 / A220

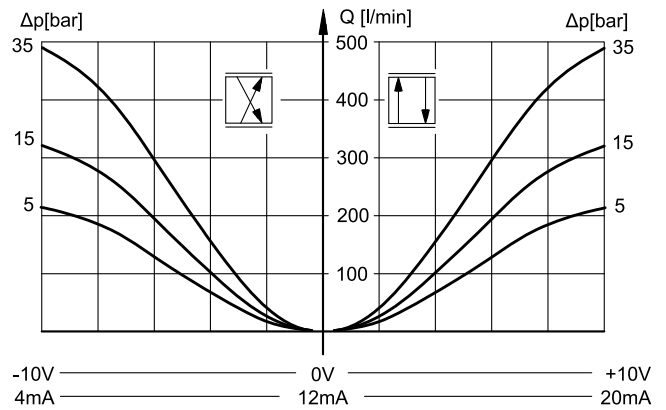

SPOOL Z120

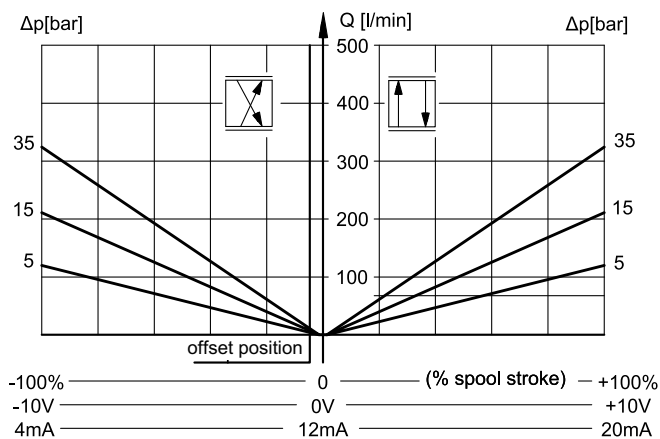

SPOOL Z220

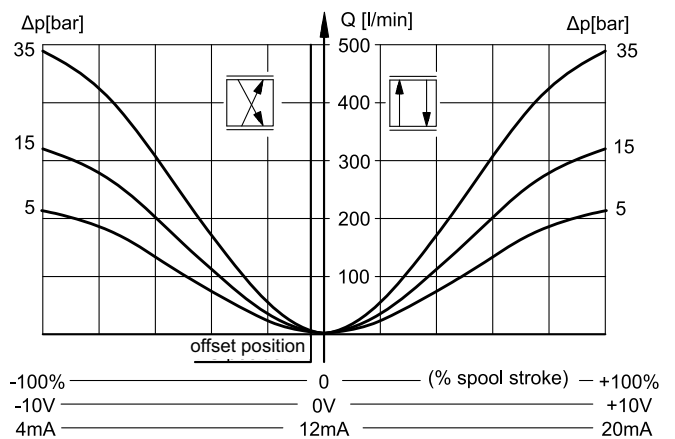

7.3 - Characteristic curves DXRE8J

SPOOL C250 / A250

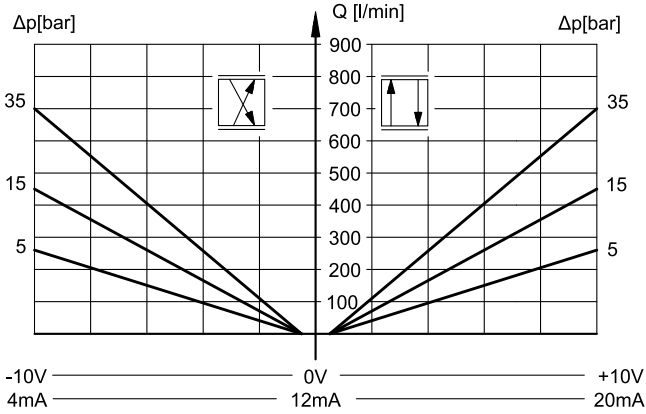

SPOOL Z250

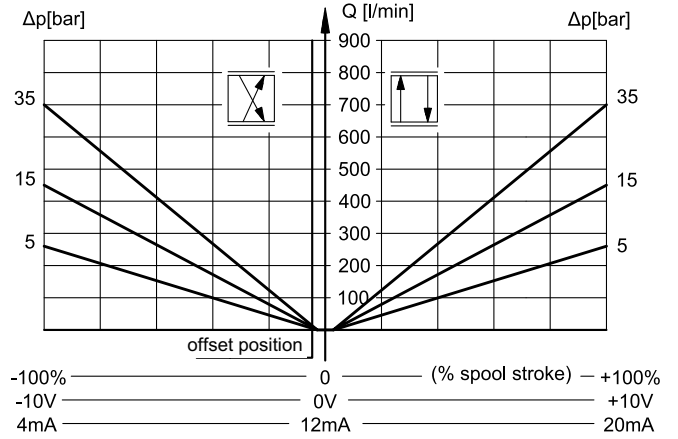

SPOOL C400 / A400

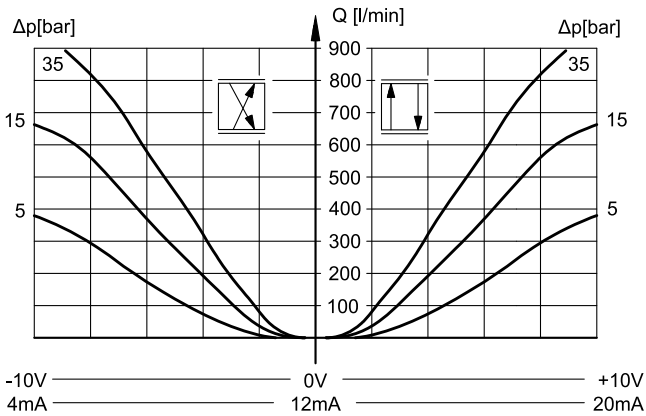

SPOOL Z400

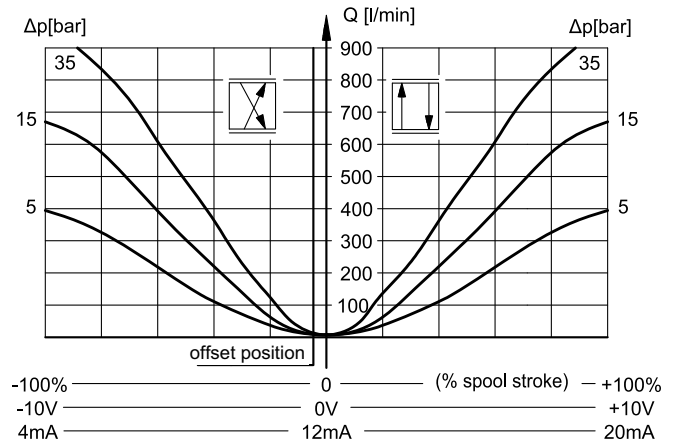

7.4 - Characteristic curves DXRE10J*

SPOOL C800

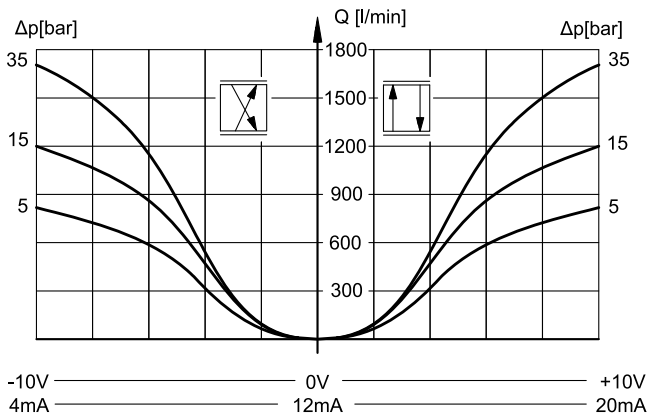

SPOOL Z800

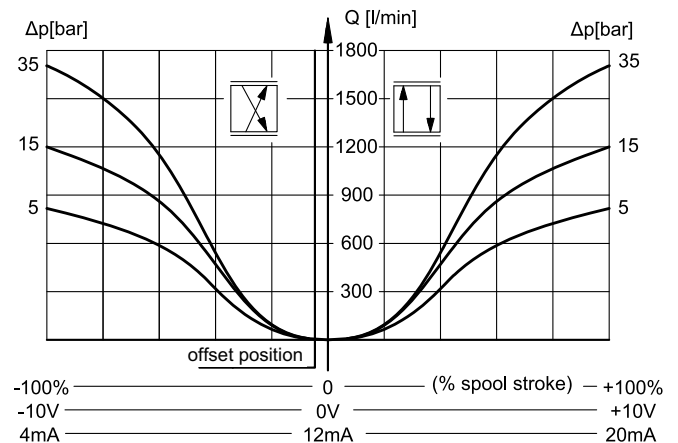



7.5 - Characteristic curves DXRE11J

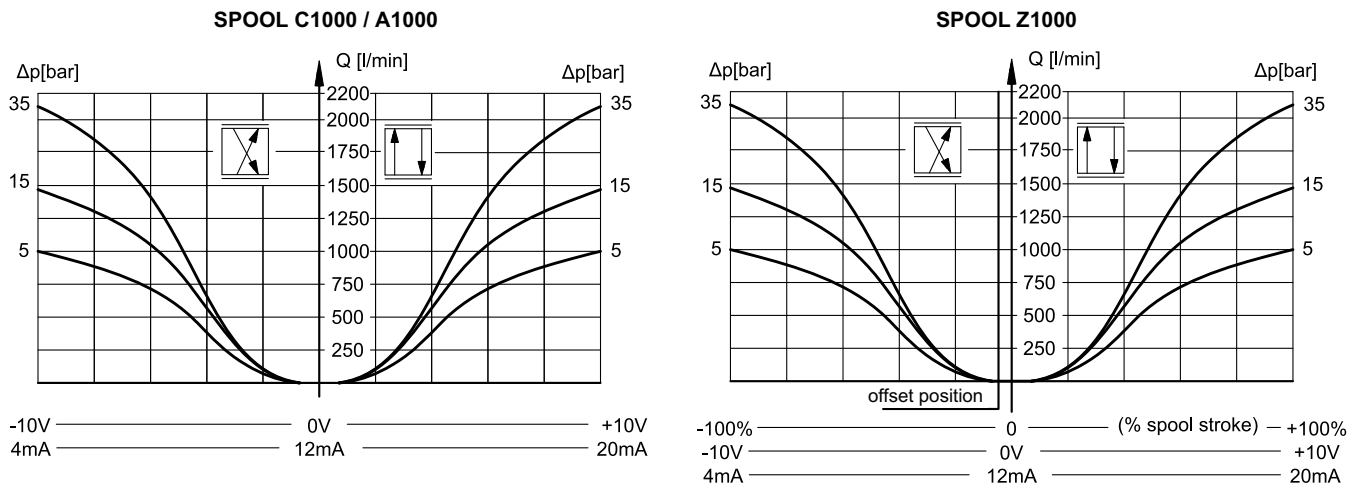

8 - RESPONSE TIMES

(obtained with mineral oil with viscosity of 36 cSt at 50°C)

The tables shows the typical step response tested with static pressure 100 bar.

8.1 - DXRE5RJ

RESPONSE TIME

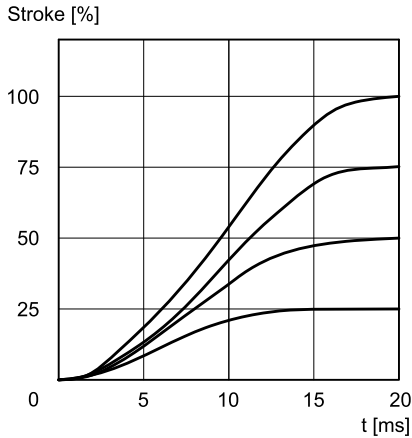

FREQUENCY RESPONSE (spools type Z)

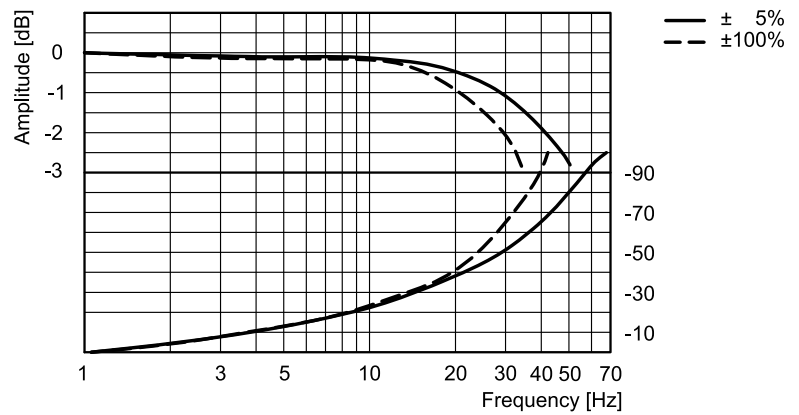

8.2 - DXRE7J

RESPONSE TIME

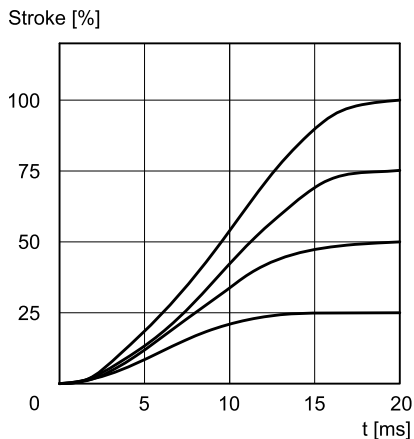

FREQUENCY RESPONSE (spools type Z)

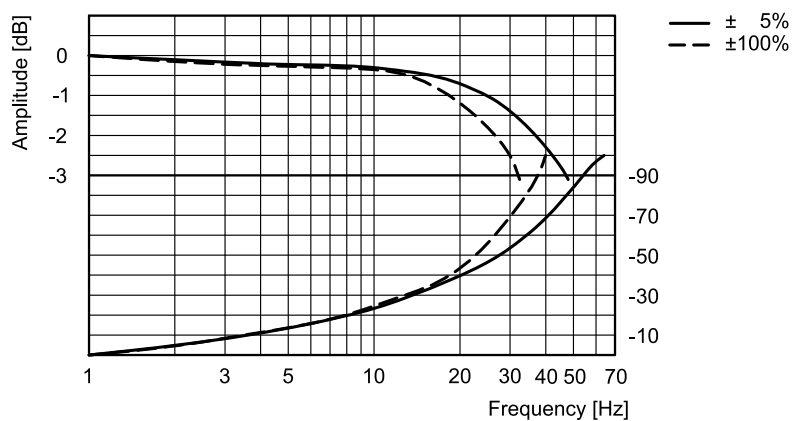



8.3 - DXRE8J

RESPONSE TIME

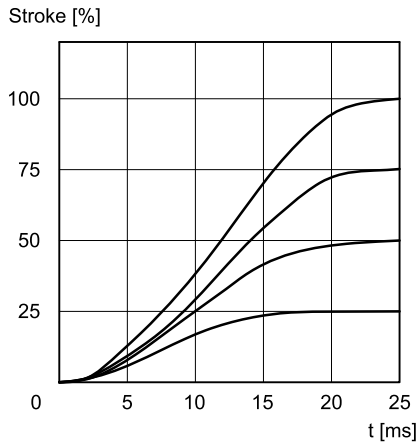

FREQUENCY RESPONSE (spools type Z)

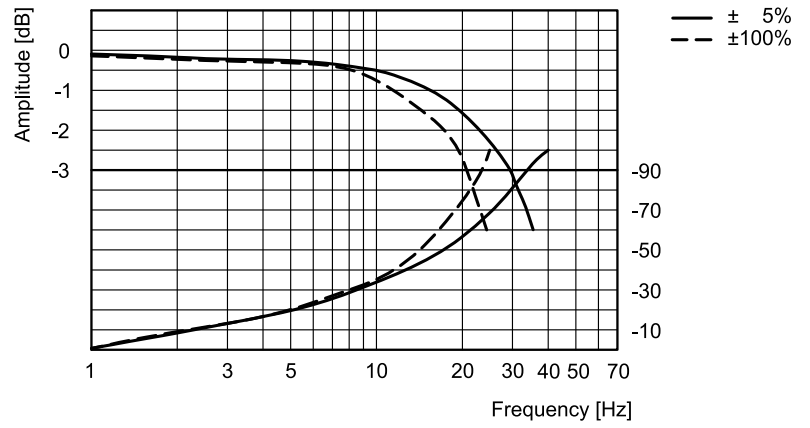

8.4 - DXRE10J and DXRE11J

RESPONSE TIME

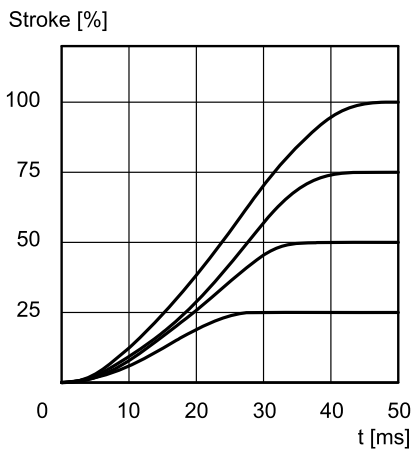

FREQUENCY RESPONSE (spools type Z)

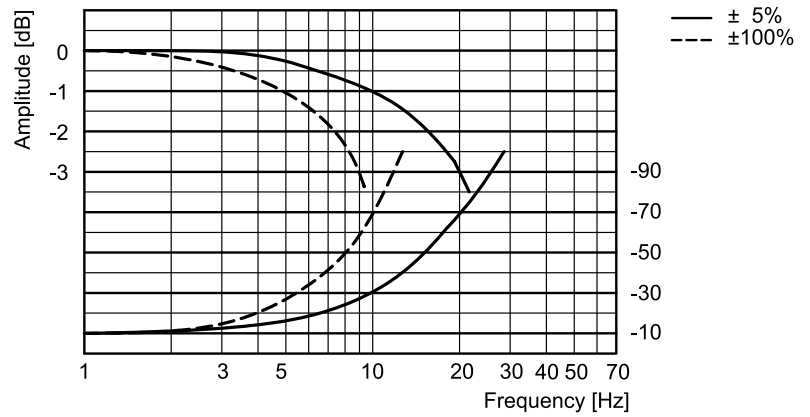



9 - HYDRAULIC CHARACTERISTICS

(with mineral oil with viscosity of 36 cSt at 50°C)

		DXRE5RJ	DXRE7J	DXRE8J	DXRE10J	DXRE11J
Max flow rate	l/min	180	450	900	1600	3500
Piloting flow requested with operation 0 → 100%	l/min	7	13	28	35	35
Piloting volume requested with operation 0 → 100%	cm ³	1.7	3.2	10	22	22

9.1 - Pilot and drain

The DXRE*J valves are available with pilot and drain both internal and external. The version with external drain allows a higher back pressure on the discharge line.

PRESSURES (bar)

Pressure	MIN	MAX
Piloting pressure on X port	15	250
Pressure on T port with internal drain	-	30
Pressure on T port with external drain	-	250

TYPE OF VALVE	Plug assembly	
	X	Y
IE INTERNAL PILOT AND EXTERNAL DRAIN	NO	YES
II INTERNAL PILOT AND INTERNAL DRAIN	NO	NO
EE EXTERNAL PILOT AND EXTERNAL DRAIN	YES	YES
EI EXTERNAL PILOT AND INTERNAL DRAIN	YES	NO

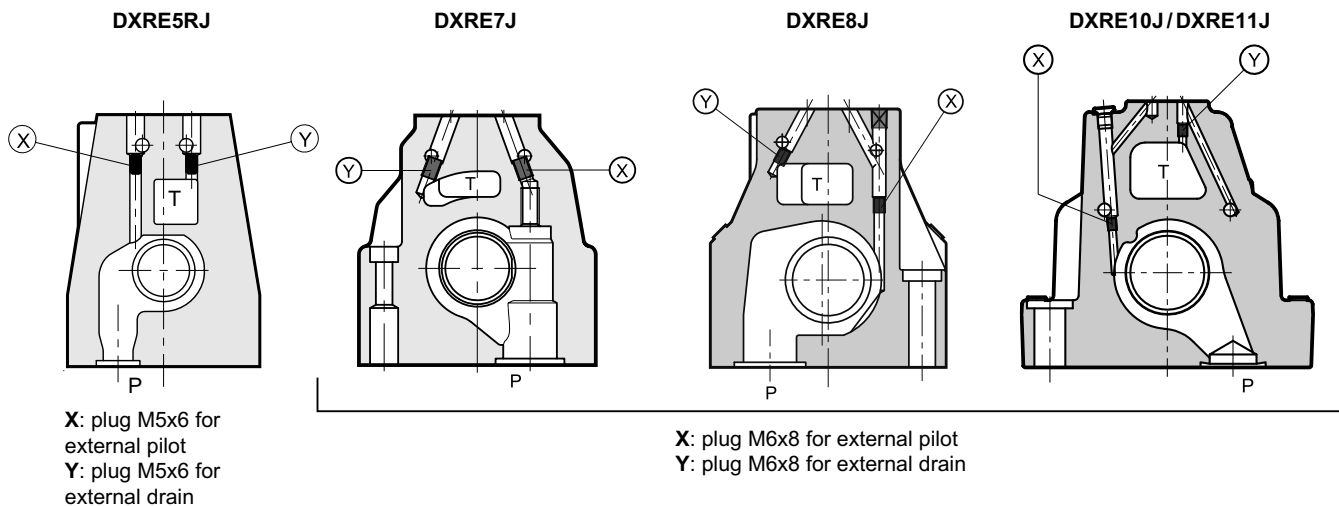

10 - OVERALL AND MOUNTING DIMENSIONS DXRE5RJ

dimensions in mm

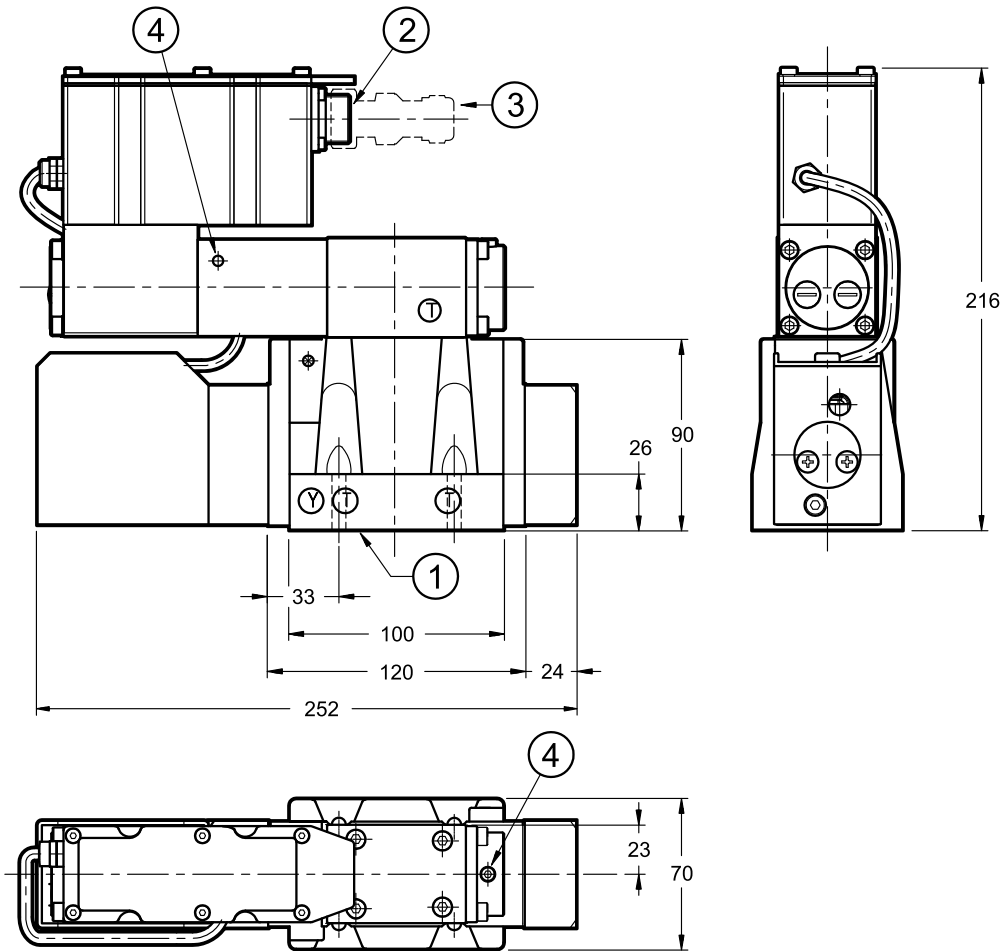

DXRE5RJH

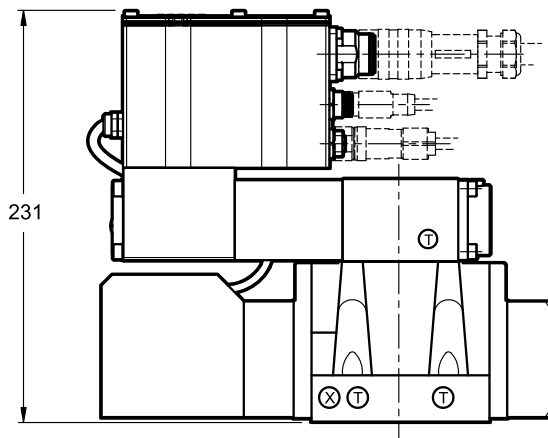

NOTES:

See mounting surface at section 14.

- Do not dismantle the transducer.

- The valve is filled with mineral oil during testing. the breathers on the pilot stage must not be opened without specific authorization.

Breaking the seals may cause the loss of the guarantee.

1	Mounting surface with sealing rings: 5 OR type 2050 (12.42x1.78) - 90 Shore 1 OR type 2037 (9.25x1.78) - 90 Shore
2	Main connection
3	Electrical connector (to be ordered separately) see paragraph 17
4	Air breather. Sealed at the factory (NOTES)

Valve fastening: N. 4 bolts M6x35 - ISO 4762

Tightening torque: 8 Nm (A8.8 screws)

Threads of mounting holes: M6x10

11 - OVERALL AND MOUNTING DIMENSIONS DXRE7J

dimensions in mm

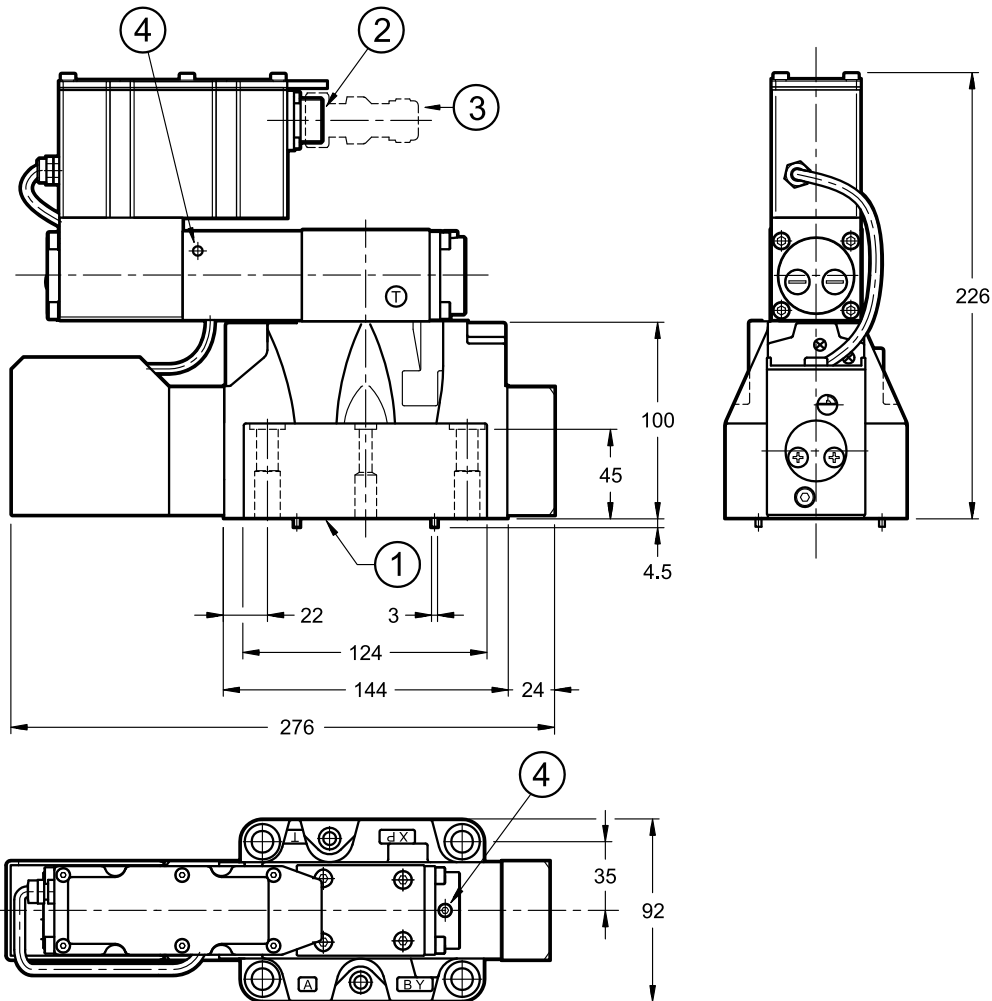

DXRE7JH

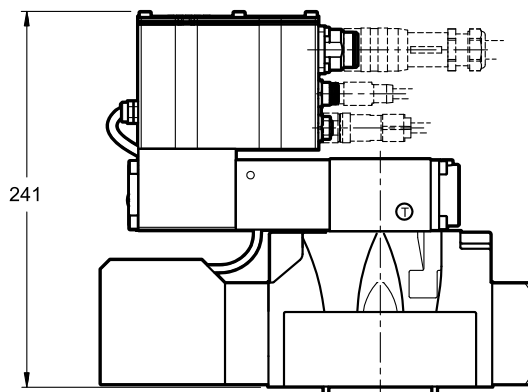

NOTES:

See mounting surface at section 14.

- Do not dismantle the transducer.

- The valve is filled with mineral oil during testing. the breathers on the pilot stage must not be opened without specific authorization.

Breaking the seals may cause the loss of the guarantee.

1	Mounting surface with sealing rings. 4 OR type 130 (22.22X2.62) - 90 Shore 2 OR type 2043 (10.82x1.78) - 90 Shore
2	Main connection
3	Electrical connector (to be ordered separately) see paragraph 17
4	Air breather. Sealed at the factory (NOTE)

Valve fastening: N. 4 bolts M10x60 - ISO 4762
N. 2 bolts M6x60 - ISO 4762

Tightening torque M10x60: 40 Nm (A8.8 screws)
M6x60: 8 Nm (A8.8 screws)

Threads of mounting holes: M6x18; M10x18

12 - OVERALL AND MOUNTING DIMENSIONS DXRE8J

dimensions in mm

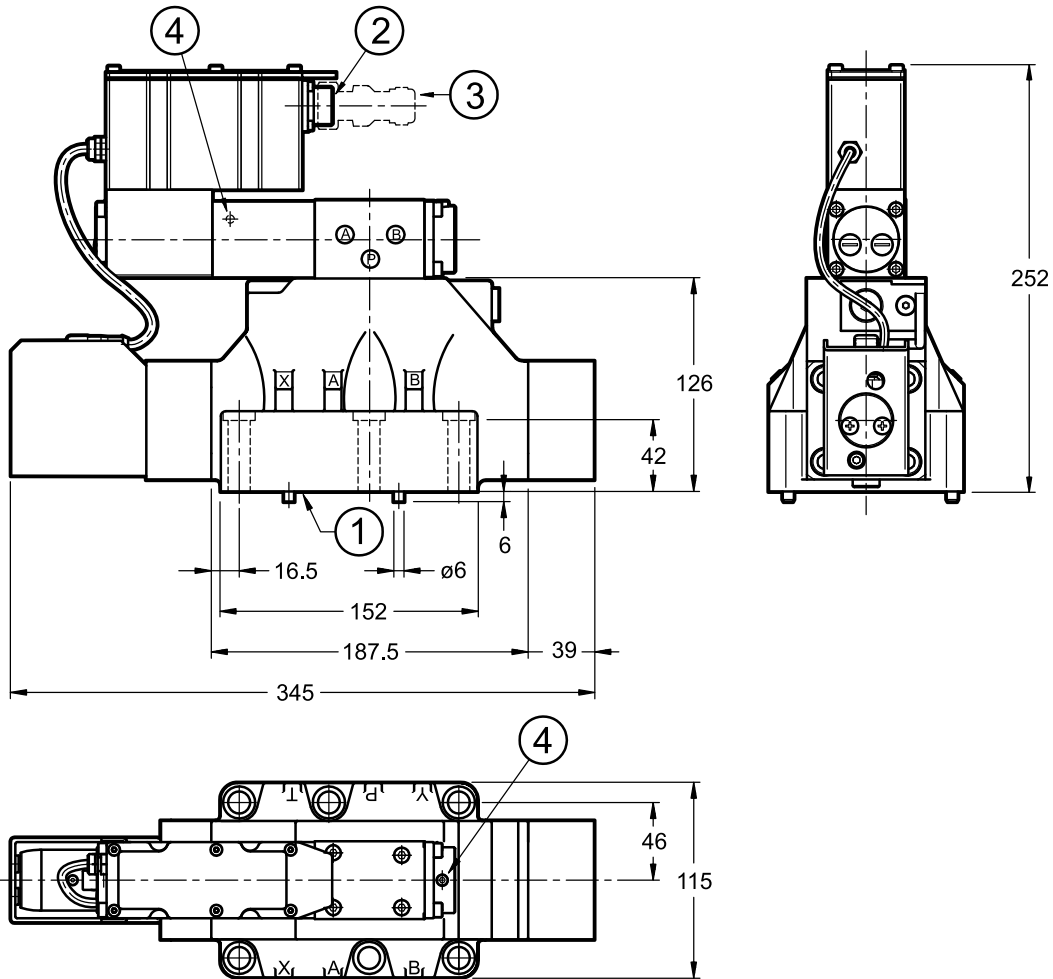

DXRE8JH

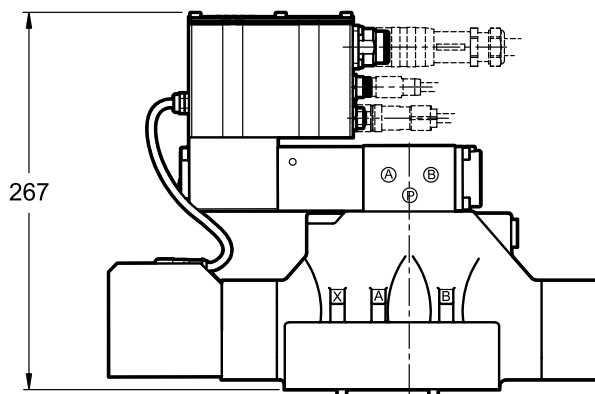

NOTES:

See mounting surface at section 14.

- Do not dismantle the transducer.

- The valve is filled with mineral oil during testing. the breathers on the pilot stage must not be opened without specific authorization.

Breaking the seals may cause the loss of the guarantee.

1	Mounting surface with sealing rings: 4 OR type 3118 (29.82x2.62) - 90 Shore 2 OR type 3081 (20.24x2.62) - 90 Shore
2	Main connection
3	Electrical connector (to be ordered separately) see paragraph 17
4	Air breather. Sealed at the factory (NOTE)

Fastening of single valve: N. 6 bolts M12X60 - ISO 4762

Tightening torque: 69 Nm (A8.8 screws)

Threads of mounting holes: M12X20

13 - OVERALL AND MOUNTING DIMENSIONS DXRE10J / DXRE11J

dimensions in mm

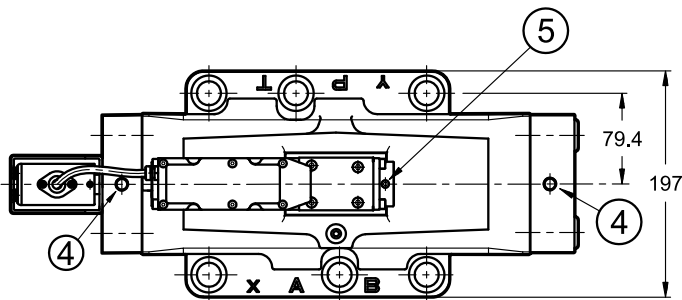
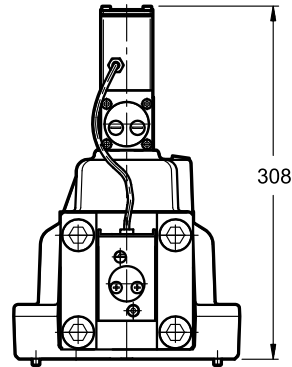
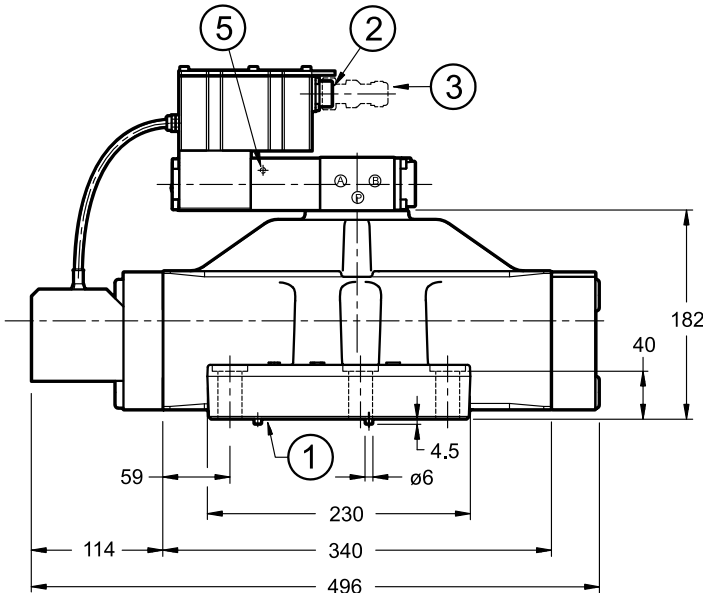

DXRE10JH

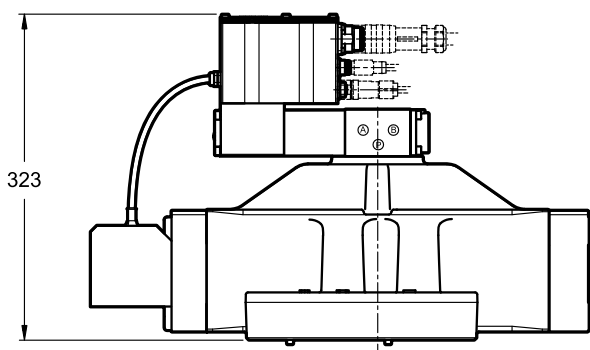

NOTES:

See mounting surface at section 14.

- Do not dismantle the transducer.

- The valve is filled with mineral oil during testing. the breathers on the pilot stage must not be opened without specific authorization.

Breaking the seals may cause the loss of the guarantee.

	Mounting surface with sealing rings: DXRE10J 4 OR type 4150 (37.59x3.53) - 90 Shore 2 OR type 3081 (20.24x2.62) - 90 Shore DXRE11J 4 OR type 4212 (53.57x3.53) - 90 Shore 2 OR type 3081 (20.24x2.62) - 90 Shore
1	
2	Main connection
3	Electrical connector (to be ordered separately) see paragraph 17
4	M12 eyebolt seat for safe lift
5	Air breather. Sealed at the factory (NOTE)

Valve fastening: 6 SHC screws ISO 4762 M20x70

Tightening torque: 330 Nm (A8.8 screws)

Threads of mounting holes: M20x40

14 - MOUNTING SURFACES

DXRE5RJ

ISO 4401-05-05-0-05
(CETOP 4.2-4 R05-350)

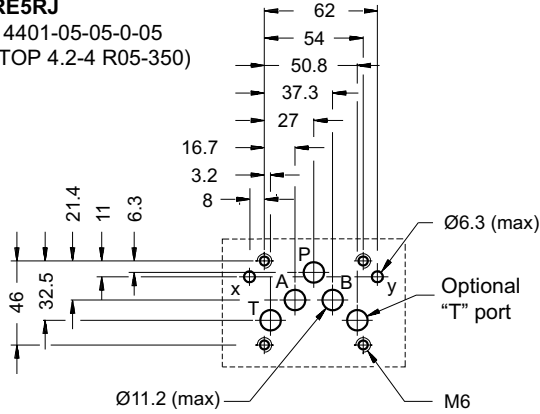

DXRE7J

ISO 4401-07-07-0-05
(CETOP 4.2-4-07-350)

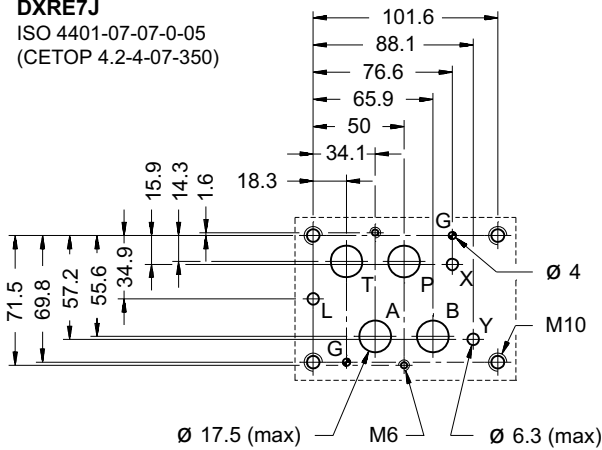

DXRE8J

ISO 4401-08-08-0-05
(CETOP 4.2-4-08-350)

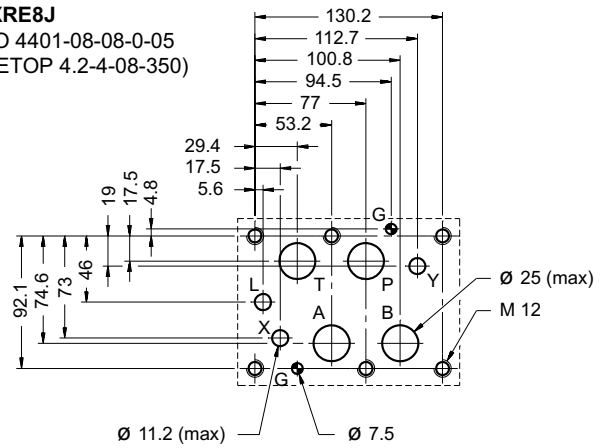

DXRE10J

ISO 4401-10-09-0-05
(CETOP 4.2-4-10-350)

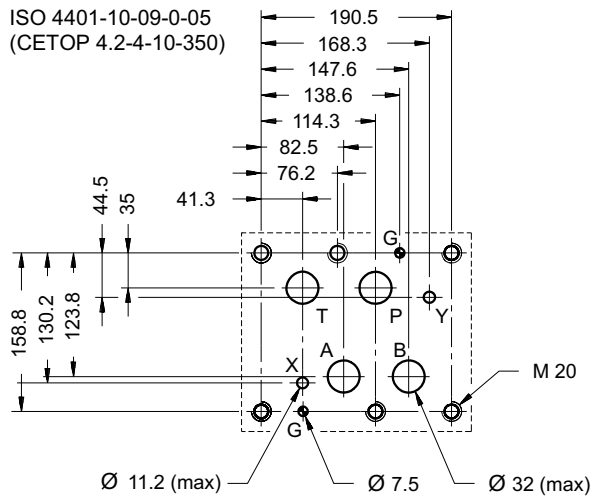

DXRE11J

ISO 4401-10-09-0-05
deviating from standard:
P, T, A, B ports Ø48

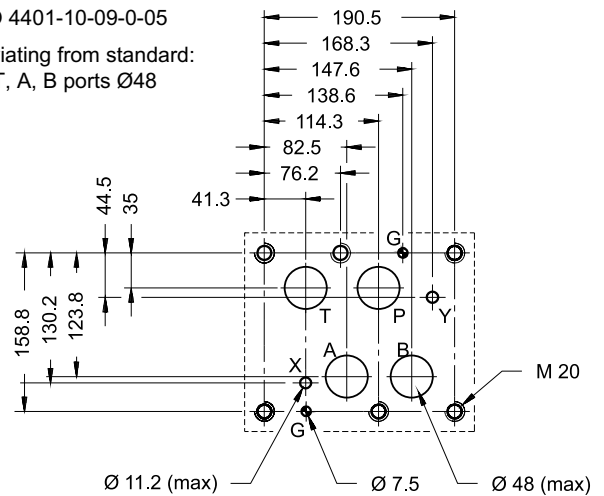



15 - HYDRAULIC FLUIDS

Use mineral oil-based hydraulic fluids HL or HM type, according to ISO 6743-4. For these fluids, use NBR seals. For fluids HFDR type (phosphate esters) use FPM seals (code V). For the use of other kinds of fluid such as HFA, HFB, HFC, please consult our technical department.

Using fluids at temperatures higher than 80 °C causes a faster degradation of the fluid and of the seals characteristics. The fluid must be preserved in its physical and chemical characteristics.

16 - INSTALLATION

The valves can be installed in any position without impairing correct operation. Make sure the hydraulic circuit is free of air.

Valves are fixed by means of screws or tie rods on a flat surface with planarity and roughness equal to or better than those indicated in the relative symbols. If minimum values are not observed, fluid can easily leak between the valve and support surface.

Take care to the cleanliness of the mounting surfaces and surrounding environment upon installation.

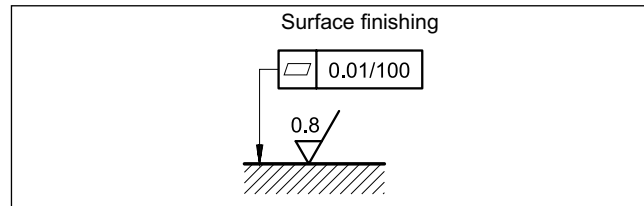

17 - ACCESSORIES

(to be ordered separately)

17.1 - Mating connectors

Mating connectors must be ordered separately. See catalogue 89 000.



We recommend the choice of a metal connector to avoid electromagnetic disturbances and to comply with EMC regulations on electromagnetic compatibility. If you opt for a plastic connector, make sure that it guarantees and maintains the IP and EMC protection characteristics of the valve.

17.2 - Mating connectors for fieldbus communication and for sensors.

Duplomatic offers spare parts to be wired and also ready-to-use cord sets. Please refer to cat. 89 000.

17.3 - Connection cable

The optimal wiring provides for 7 isolated conductors, with separate screen for the signal wires (command, monitor) and an overall screen.

Cross section for power supply:

- up to 20 m cable length : 1,0 mm²
- up to 40 m cable length : 1,5 mm²

Cross section for signals (command, monitor):

- 0,50 mm²

17.4 - Kit for start-up LINPC-USB

Device for service start-up and diagnostic. See catalogue 89 850.

18 - SUBPLATES

(see catalogue 51 000)

Subplates are not available for DXRE5RJ, DXRE10J and DXRE11J.

	DXRE7J	DXRE8J
with rear ports	PME07-AI6G	-
with side ports	PME07-AL6G	PME5-AL8G
thread of ports:	P - T - A - B X - Y	1" BSP 1/4" BSP
		1 1/2" BSP 1/4" BSP