

Air Shut-Off valves series VSA

Air solenoid shut-off valve of series VSA are suitable for high / low operation, these valves, normally closed for continuous and cyclic operation, open slowly by powering the coil and close slowly when there is no tension.

The speed time of opening/closing operation can be set in any value between 1 and 15 seconds.

These range of air solenoid valves are manufactured in conformity to norm EN 161 and regulation EU 2016/426.



TECHNICAL FEATURES

Valve body	Die-cast aluminium
Threaded connections	Rp 1.1/4 ÷ Rp 2 according to EN10226
Flanged connections	DN65 ÷ DN80 according to ISO 7005
Max Inlet pressure	200 - 360 mbar
Opening/closing time	Adjustable up to 15 seconds
Standard supply voltage	230V ac, 110V ac, 24V ac and dc
Frequency	50 ÷ 60 Hz - 50 Hz for 24 Vac
Enclosure	IP 65 - IEC 529
Supply voltage tolerance	-15% - +10%
Duty cycle	Continuous
Ambient temperature	-20 / +60 °C

FEATURES

- Class A, Group 2 according to EN161
- Electromagnetic Compatibility - Directive 2004/108/CE
- Low voltage - Directive 2006/95/CE
- Normally closed
- Slow opening/closing time adjustable, rapid stroke
- Pressure test points at inlet by both sides

MODELS

VSA = Shut-off valve in aluminium

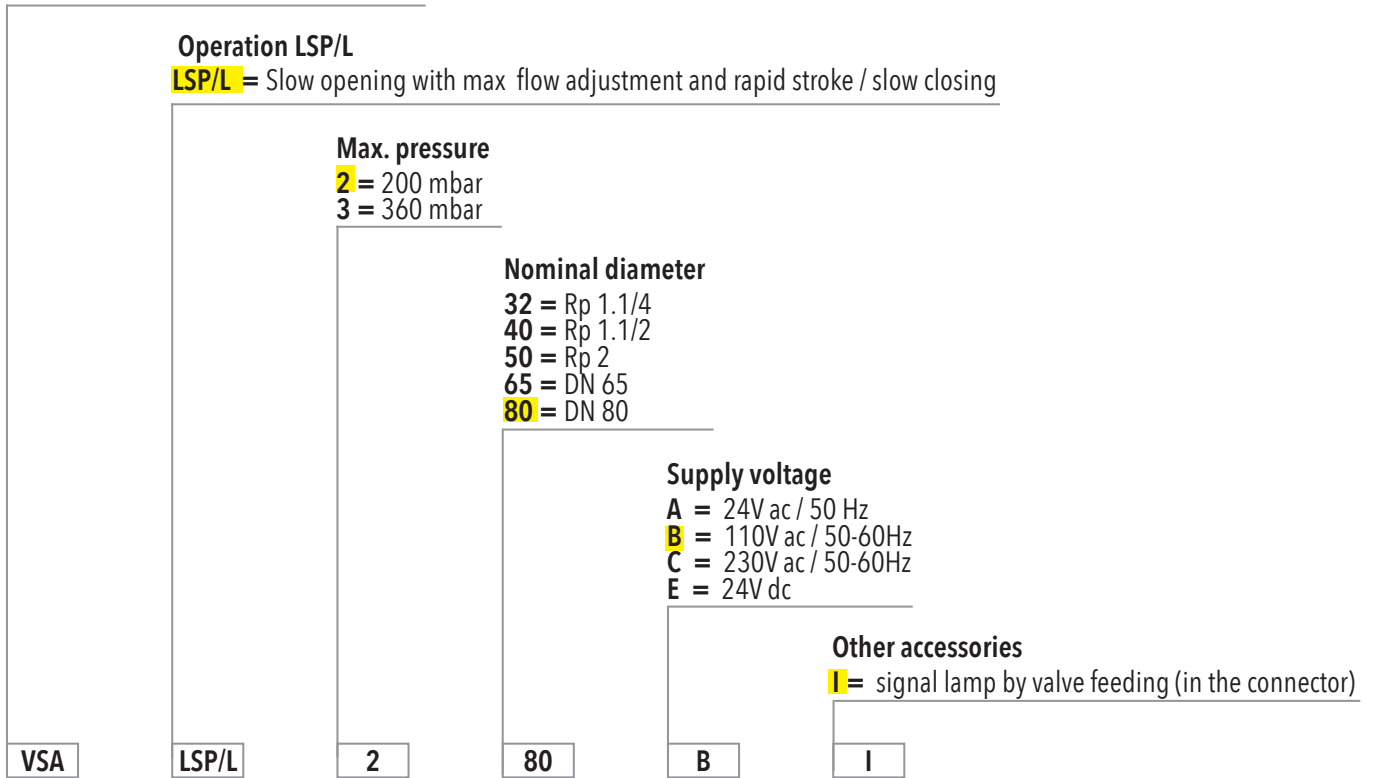

FLOW CHART

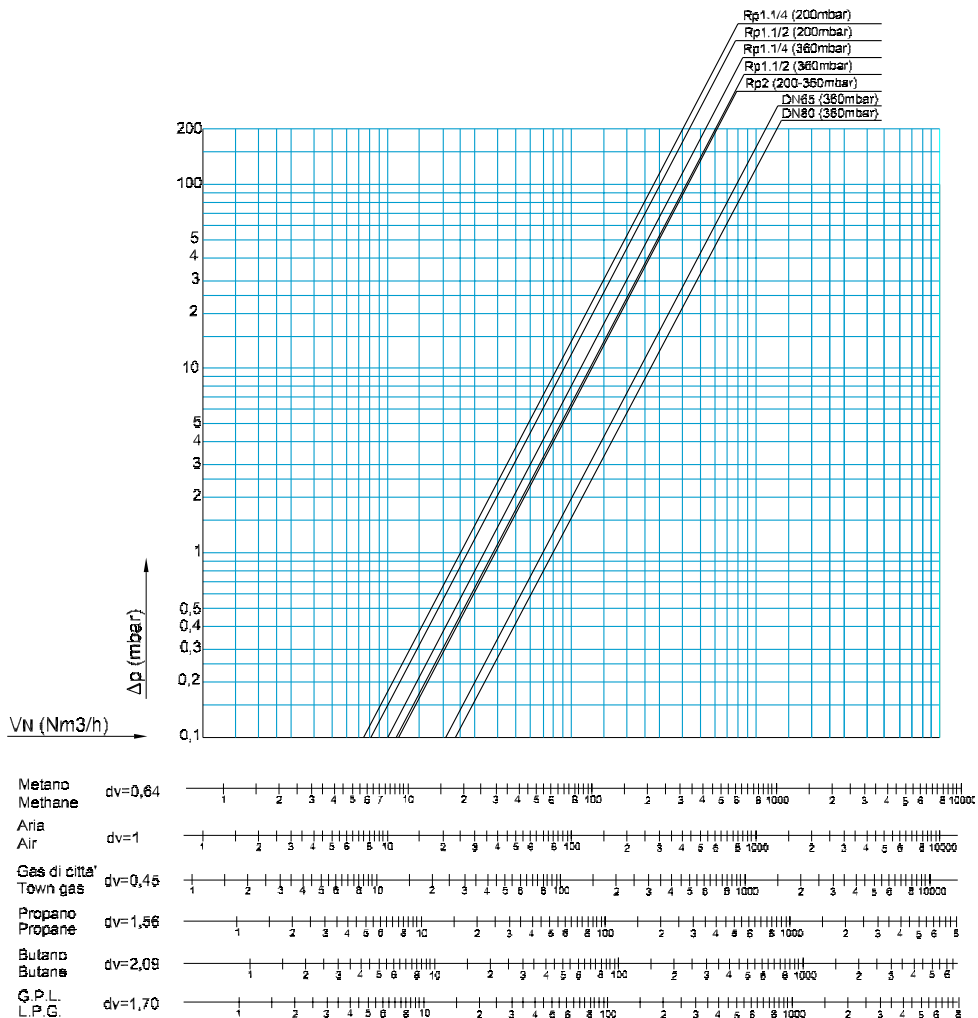

MODELS AND RATING

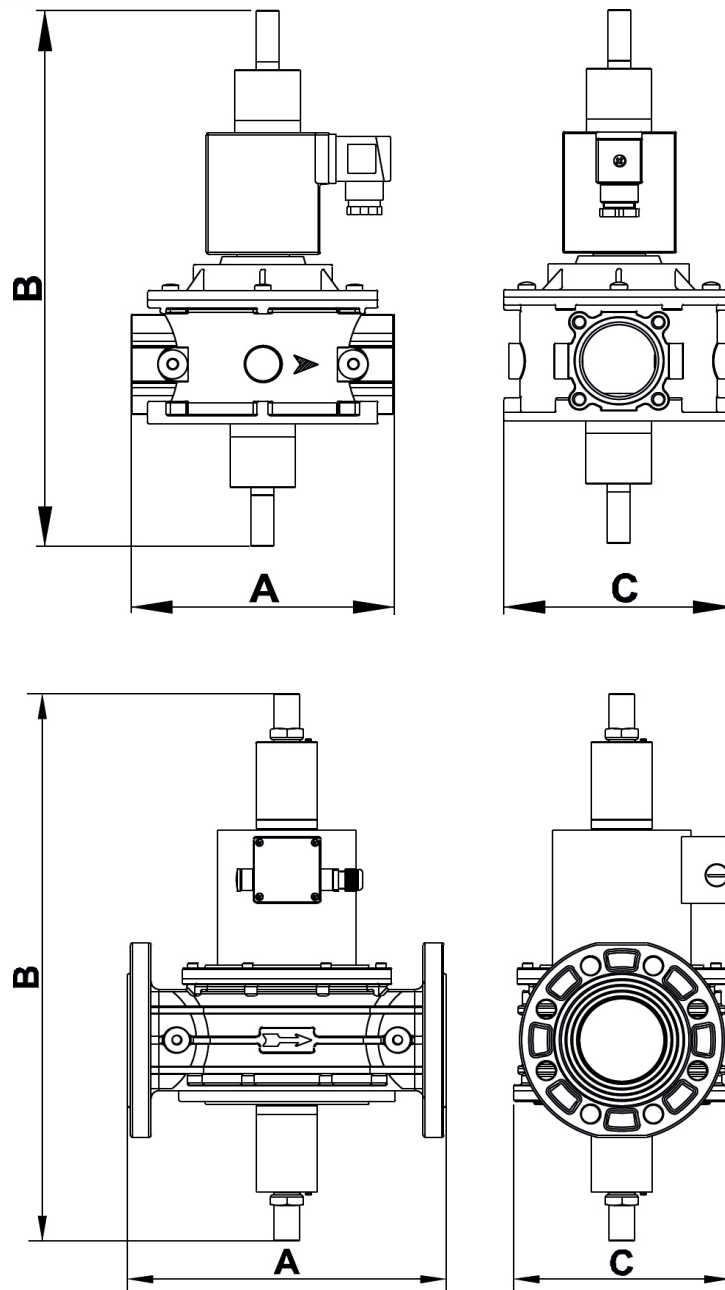

Pipe	Max. pressure (mbar)	Rating at a 230V (VA)	Dimensions (mm)			Weight (Kg)	Model
			A	B	C		
1.1/4"	200	89 / 25	160	339	140	3,5	VSALSP-L232..
	360			352		3,7	VSALSP-L332..
1.1/2"	200	89 / 25	160	339	140	3,5	VSALSP-L240..
	360			352		3,7	VSALSP-L340..
2"	200	89 / 25	160	370	140	3,8	VSALSP-L250..
	360			380			VSALSP-L350..
DN65	360	105 / 29	290	639	211	17	VSALSP-L365..
DN80			310	644	211	17	VSALSP-L380..

WIRING INSTRUCTIONS



WARNING

Installation, adjustment and maintenance of the valve must be carried out exclusively by skilled and authorized service technicians

1. Before electric wiring, check that the main voltage matches with the power supply voltage stated on the product label.
2. Disconnect power before wiring.
3. By wiring connector, use terminals and cables as reported in the Instruction leaflet in the package.
4. Connect the power supply to terminals 1 and 2 and the ground wire to terminal
5. Using energy saving connector with 24V dc comply with polarity.

INSTALLATION AND OPERATING INSTRUCTIONS

1. Make sure that all operating data indicated on the safety shut-off valve label correspond to those of the system.
2. Before installing the safety shut-off valve, quit the gas supply and make sure that the pipeline is free from impurities. The pipeline must be vibration-free.
3. The flow direction indicated by the arrow on the valve body must be respected, facing towards the user appliance. The safety valve can be installed either horizontally or vertically, provided that the coil is not turned downwards.
4. When installing the safety shut-off valve in pipework do not use the coil as a lever, but use the correct wrench.
5. The sealing material must be applied to the external thread of the pipeline only and not to the internal thread of the safety shut-off valve.

ADJUSTMENT OF FLOW RATE - OPENING TIME AND RAPID STROKE

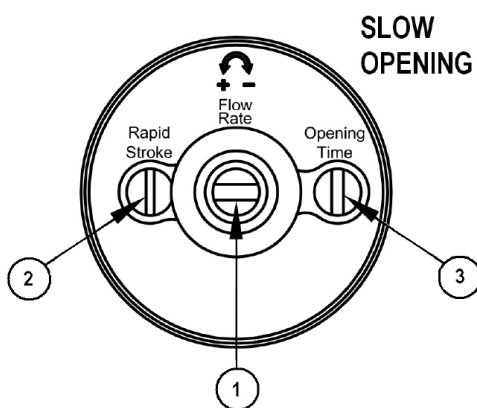

1. Flow rate adjustment

Unscrew the nut and spin the internal screw clockwise ↻ to reduce and counter clockwise ↻ to increase the flow rate.

2. Rapid stroke adjustment

3. Opening time adjustment

Spin the screws clockwise ↻ to reduce each worth and counter clockwise ↻ to increase each worth.

All the reported data are subject to be changed without notice.

form 180911

econex

Econex s.r.l. - Via Francesco De Sanctis, 53 - I-20141 Milano
Tel. +39 0289502912 - Fax +39 028463084 - www.econex.it - info@econex.it