



PCM8

TWO- AND THREE-WAY PRESSURE COMPENSATOR WITH FIXED ADJUSTMENT

SERIES 10

MODULAR VERSION ISO 4401-08

p max 320 bar
Q max 300 l/min

MOUNTING INTERFACE

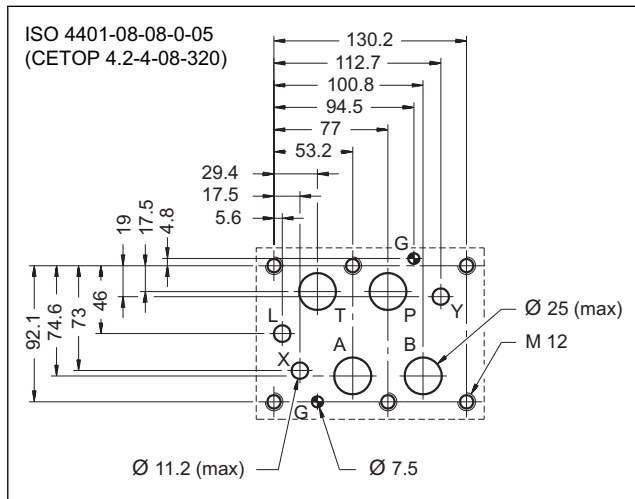

APPLICATION EXAMPLES

Two-way compensator with fixed adjustment and internal piloting, combined with a proportional valve type DSPE8-A*

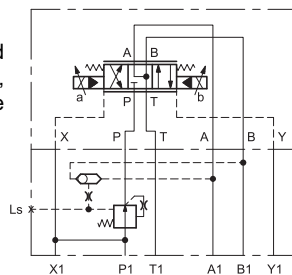

PERFORMANCES (with mineral oil of viscosity of 36 cSt at 50°C)

Max operating pressure	bar	320
Characteristic Δp	bar	4 - 8
Max flow rate	l/min	300
Ambient temperature range	°C	-20 / +60
Fluid temperature range	°C	-20 / +80
Fluid viscosity range	cSt	10 ÷ 400
Fluid contamination degree	According to ISO 4406:1999 class 20/18/15	
Recommended viscosity	cSt	25
Mass	kg	13,5

OPERATING PRINCIPLE

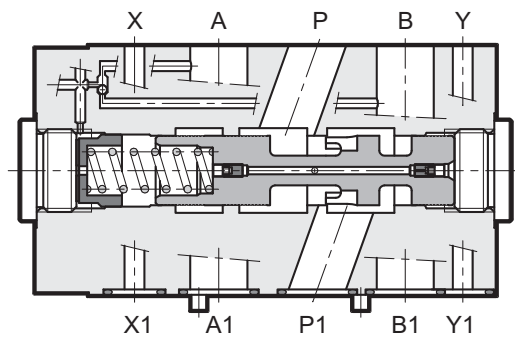

- The PCM8 valve is a two or three-way pressure compensator, developed as a modular version with mounting surface according to ISO 4401-08.
- Its function is to keep the pressure drop setting (characteristic Δp) between the line P and alternatively the lines A and B at a constant level.
- It is normally used together with proportional directional valves, in order to control the flow rate independently of the pressure variations.
- The selection of the piloting pressure on the lines A and B is carried out automatically via a shuttle check valve built into the compensator.
- They are available with fixed adjustment (characteristic Δp) of 4 and 8 bar.

— The load sensing port can also be used as pressure gauge port or as remote pressure control.

1 - IDENTIFICATION CODE

1.1 - Two-way compensator

P	C	M	8	-	P	/	E	/	10
----------	----------	----------	----------	----------	----------	----------	----------	----------	-----------

Pressure compensator

Modular version

Nominal size ISO 4401-08

2 ways

Adjustment: **4** = 4 bar
8 = 8 bar

Piloting: (relevant to the combined directional valve, that must always have external piloting)
I = internal (withdrawn inside the compensator, upstream the narrowing)
E = external (passing line X)

Seals:
N = NBR seals for mineral oils (**standard**)
V = FPM seals for special fluids

Series no.:
(the overall and mounting dimensions remain unchanged from 10 to 19)

External drain (passing line Y)

Hydraulic symbols

PCM8-P*/IE/10 PCM8-P*/EE/10

1.2 - Three-way compensator

P	C	M	8	-	PT	/	E	/	10
----------	----------	----------	----------	----------	-----------	----------	----------	----------	-----------

Pressure compensator

Modular version

Nominal size ISO 4401-08

3 ways

Adjustment: **4** = 4 bar
8 = 8 bar

Piloting: (relevant to the combined directional valve, that must always have external piloting)
I = internal (withdrawn inside the compensator, upstream the narrowing)
E = external (passing line X)

Seals:
N = NBR seals for mineral oils (**standard**)
V = FPM seals for special fluids

Series no.:
(the overall and mounting dimensions remain unchanged from 10 to 19)

External drain (passing line Y)

Hydraulic symbols

PCM8-PT*/IE/10 PCM8-PT*/EE/10

2 - CHARACTERISTIC CURVES

(values obtained with viscosity of 36 cSt at 50°C)

2.1 - Two-way compensator

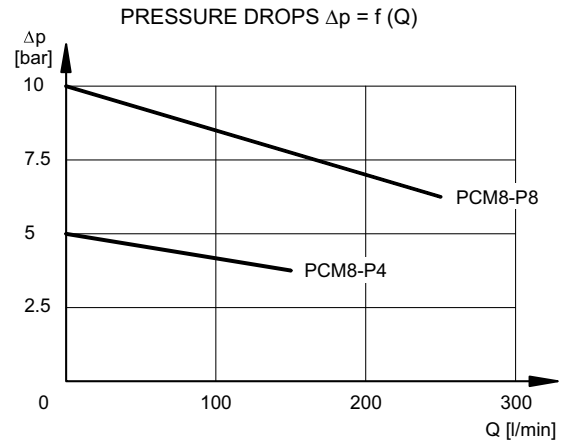
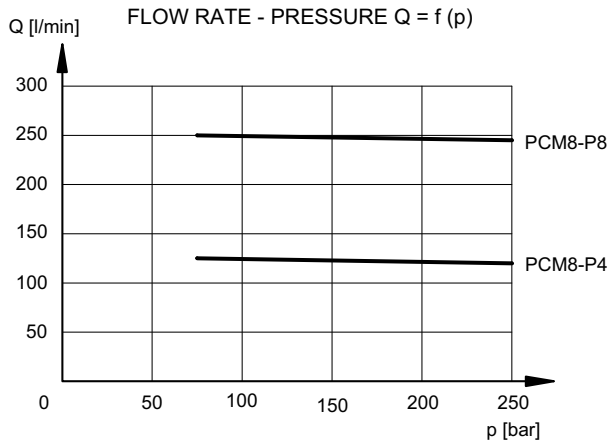

2.2 - Three-way compensator

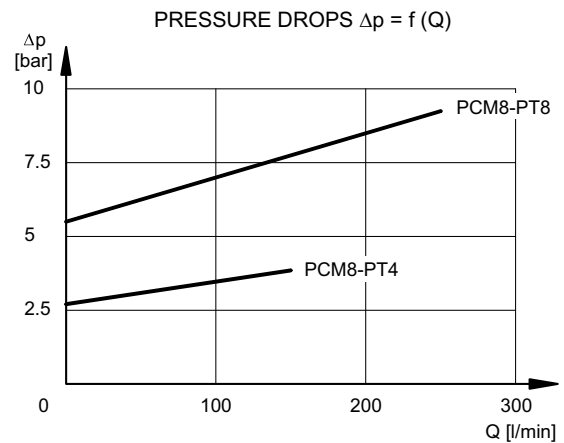
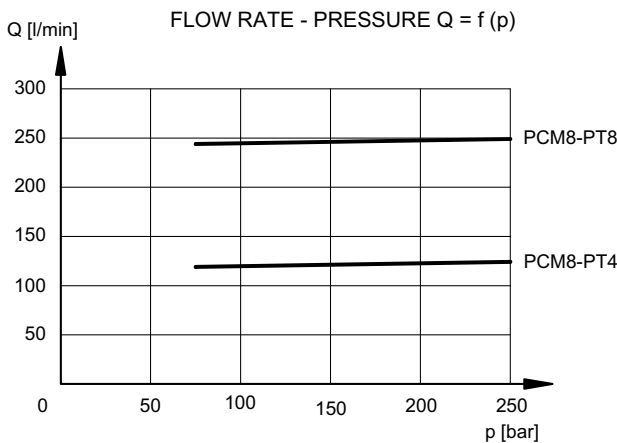

3 - HYDRAULIC FLUIDS

Use mineral oil-based hydraulic fluids HL or HM type, according to ISO 6743-4. For these fluids, use NBR seals. For fluids HFDR type (phosphate esters) use FPM seals (code V). For the use of other kinds of fluid such as HFA, HFB, HFC, please consult our technical department. Using fluids at temperatures higher than 80 °C causes a faster degradation of the fluid and of the seals characteristics.

The fluid must be preserved in its physical and chemical characteristics.

4 - PILOT AND DRAIN

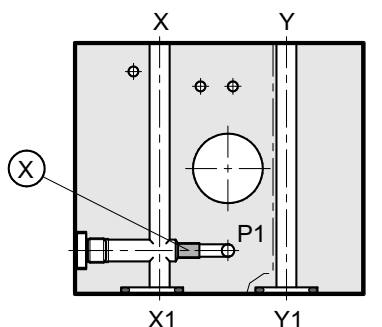

X: plug M6x10 for external pilot
Drain always external

The PCM8 compensators are available with the X pilot line both internal and external. The internal pilot line is withdrawn from the P1 line, upstream the narrowing of the compensator, while the external pilot line comes from a separate pilot circuit. Drain is always external (passing line Y).

The combined directional valve must always have an external pilot configuration. Drain can be both internal and external.

VALVE TYPE		X plug
PCM8-P*/IE	INTERNAL PILOTING AND EXTERNAL DRAINAGE	NO
PCM8-P*/EE	EXTERNAL PILOTING AND EXTERNAL DRAINAGE	YES

5 - OVERALL AND MOUNTING DIMENSIONS

