

P4D-RQM5

MODULAR SUBPLATE WITH PRESSURE RELIEF VALVE AND UNLOADING SOLENOID VALVE

SERIES 30

p max 350 bar
Q max 250 l/min

OPERATING PRINCIPLE

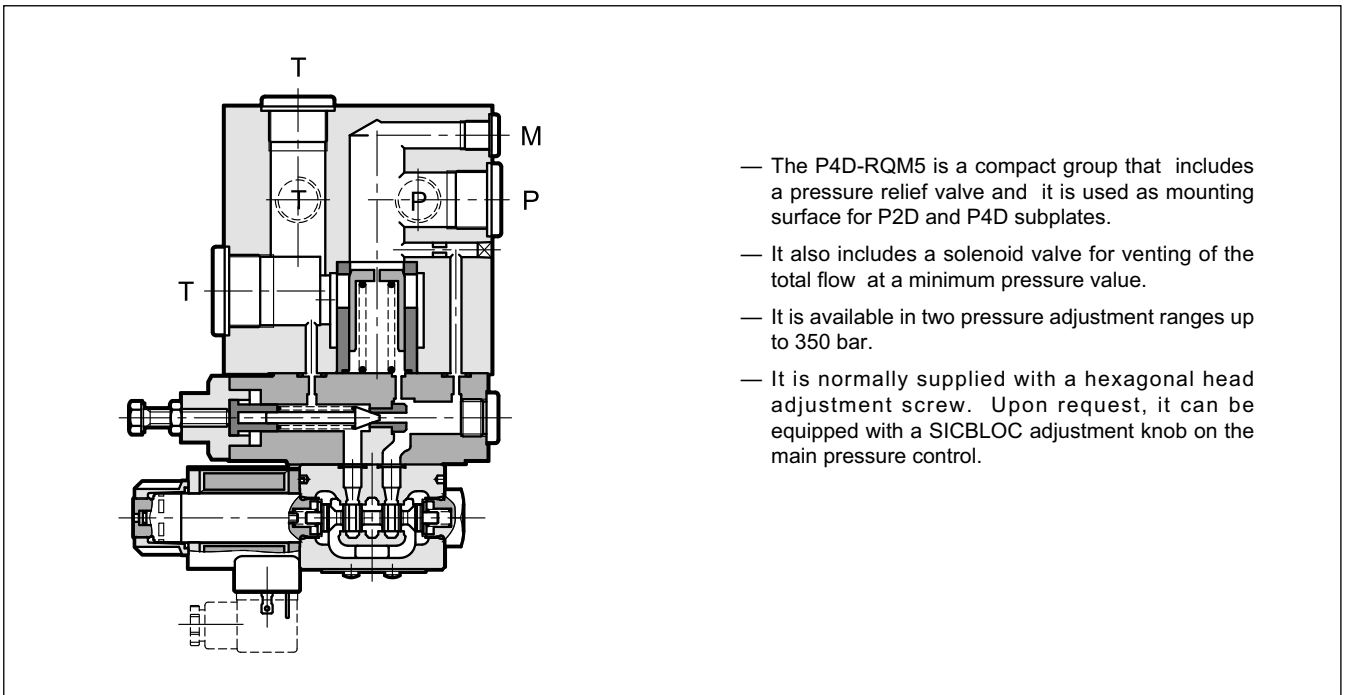

PERFORMANCES (measured with mineral oil of viscosity 36cSt at 50°C)

Maximum operating pressure	bar	350
Maximum flow on P (3/4") and T(1")	l/min	250
Maximum flow on P ₁ and T ₁ (1/2")		120
Minimum flow		10
Ambient temperature range	°C	-20 / +50
Fluid temperature range	°C	-20 / +80
Fluid viscosity range	cSt	10 ÷ 400
Fluid contamination degree	According to ISO 4406:1999 class 20/18/15	
Recommended viscosity	cSt	25
Mass	kg	10

NOTE: for the solenoid valve DS3 characteristics see catalogue 41 150.

HYDRAULIC SYMBOL

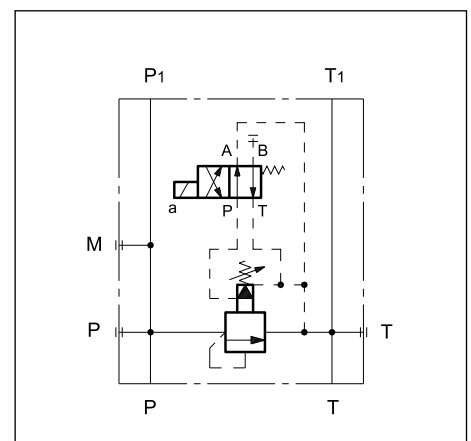

1 - IDENTIFICATION CODE

P	4	D	-	R	Q	M	5	-	/	/	30	-	K1	/	
---	---	---	---	---	---	---	---	---	---	---	----	---	----	---	--

Subplate
ISO 4401-05 dimension

Pressure relief valve
with unloading solenoid valve

ND 25 nominal dimension

Pressure adjustment range
5 = 250 bar 6 = 350 bar

M = SICBLOC adjustment knob
(omit for hexagonal head adjustment screw)

Series (the overall and mounting dimensions
remain unchanged from 30 to 39)

Seals:
N = NBR seals for mineral oil (**standard**)
V = FPM seals for special fluids

NOTE: The locking rings of the coils and the relevant O-Rings are supplied together with valves.

Manual override:
omit for override
integrated in the
tube (**standard**)
CM = manual
override, boot
protected

Coil electrical connection:
plug for connector type
EN 175301-803
(ex DIN 43650) (**standard**)

DC power supply
D12 = 12 V
D24 = 24 V
D48 = 48 V
D110 = 110 V
D220 = 220 V
D00 = valve without coils (see **NOTE**)

AC power supply
A24 = 24 V - 50 Hz
A48 = 48 V - 50 Hz
A110 = 110 V - 50 Hz / 120 V - 60 Hz
A230 = 230 V - 50 Hz / 240 V - 60 Hz
A00 = valve without coils (see **NOTE**)
F110 = 110 V - 60 Hz
F220 = 220 V - 60 Hz

2 - CHARACTERISTIC CURVES

(values obtained with viscosity of 36 cSt at 50°C)

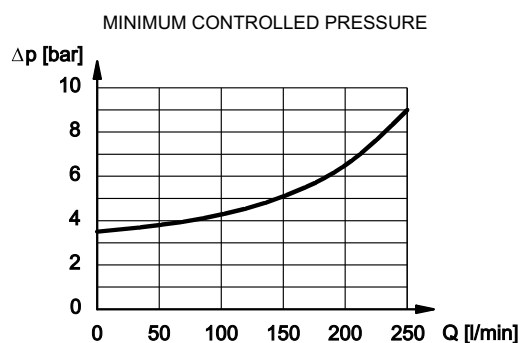
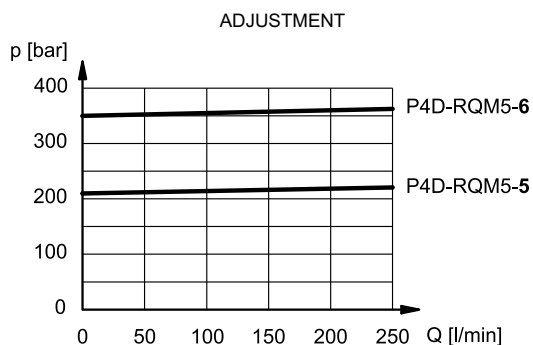

NOTE: The maximum flow deliverable to P1 port is 120 l/min (for P2D and P4D modular subplates).
The maximum flow through the pressure relief valve (additional 3/4" BSP P port) is 250 l/min.

3 - HYDRAULIC FLUIDS

Use mineral oil-based hydraulic fluids HL or HM type, according to ISO 6743-4. For these fluids, use NBR seals. For fluids HFDR type (phosphate esters) use FPM seals (code V). For the use of other kinds of fluid such as HFA, HFB, HFC, please consult our technical department.

Using fluids at temperatures higher than 80 °C causes a faster degradation of the fluid and of the seals characteristics. The fluid must be preserved in its physical and chemical characteristics.

4 - OVERALL AND MOUNTING DIMENSIONS

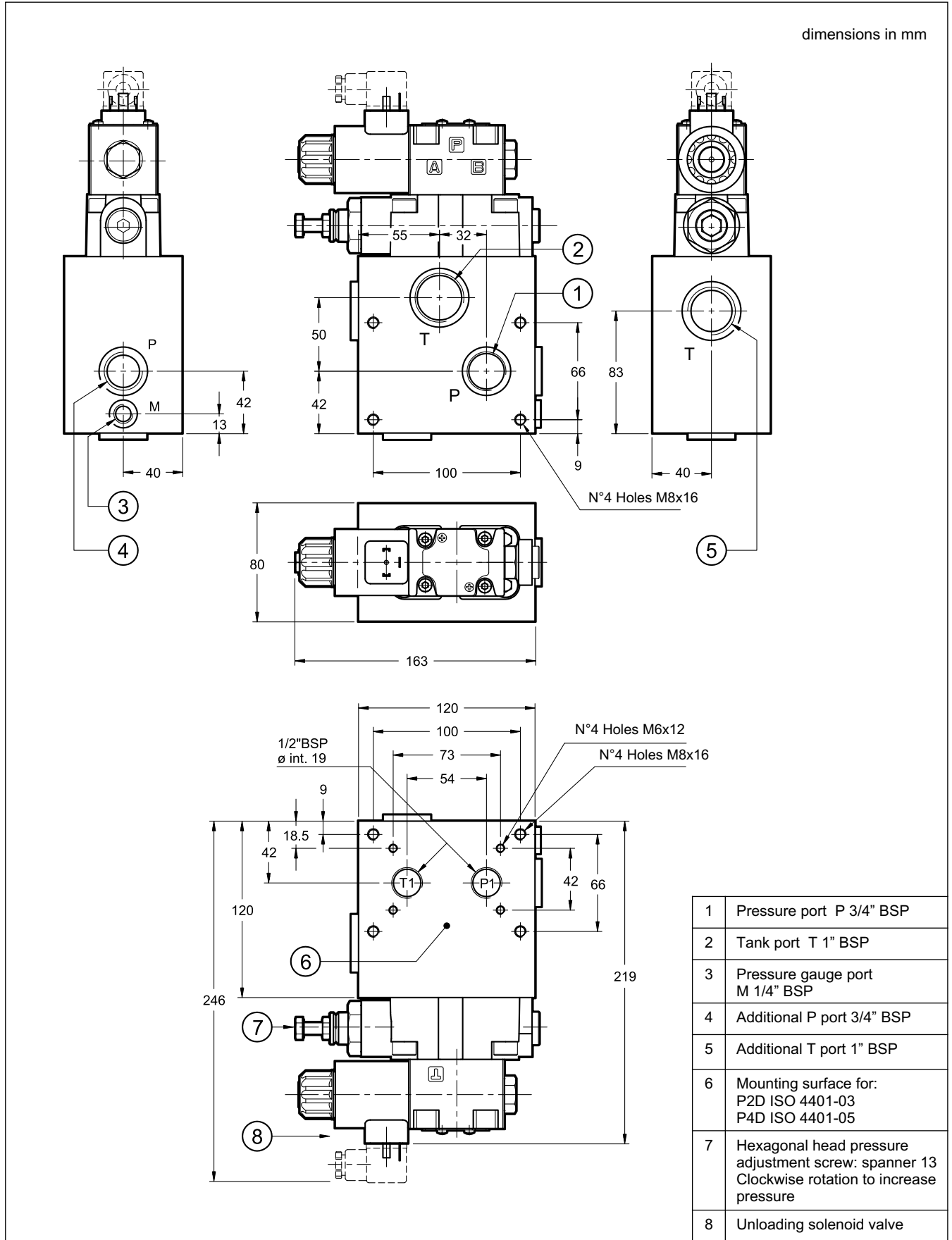



P4D-RQM5

SERIES 30

5 - ADJUSTMENT KNOB

The P4D-RQM5 valves can be equipped with a SICBLOC adjustment knob.

To operate it, push and rotate at the same time.

To request this option, add: **/M** (see paragraph 1).

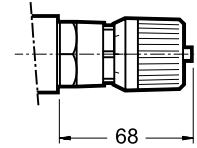

6 - ELECTRIC CONNECTORS

Solenoid operated valves are delivered without connectors.

Connectors type EN 175301-803 (ex DIN 43650) for K1 connections can be ordered separately. See catalogue 49 000.

7 - MANUAL OVERRIDE, BOOT PROTECTED: CM

Whenever the solenoid valve installation may involve exposure to atmospheric agents or utilization in tropical climates, use of the manual override, boot protected, is recommended.

Add the suffix **CM** to request this device (see paragraph 1).

For overall dimensions see catalogue 41 150.