

Tight butterfly valve series VFW and VFL

Tight butterfly valves of series VFW and VFL are installed by various industrial plants, for both shut-off and regulation purposes of air and gas belonging to the first, second and third family and other non-corrosive fluids.

This range of butterfly valves bring the advantage to have a limited dimensions and light weight, seat in NBR or viton with internal metal ring guarantees further to the dimensional and geometrical stability, an easily replacement of the seat in case of accidental damage.

Model VFW is a wafer type of butterfly valve and model VFL is a lug type; both are equipped with a yellow lever and on request can be supplied with electric or pneumatic actuator.

Butterfly valves VFW and VFL have a declaration of conformity to norms EN 161 and PED directive 97/23/PED



TECHNICAL FEATURES

Valve body	Cast-iron GJS400 painted
Butterfly disc	Cast-iron GJS400, on request in inox
Seat	NBR (EPDM or VITON on request)
Diameters	DN25 ÷ DN350 PN16
Max pressure	16 bar
Max temperature	-10 ÷ +80°C in NBR -25° ÷ +100 in EPDM
Hand lever	painted aluminium and cast iron

FEATURES

- Solid and consistent construction suitable of industry application
- Perfect internal and external tightness
- Motorized version available with electric floating or analogical actuator or with pneumatic actuator simple or double effect
- Lockable version, gear box and limit switch available on request

VFW wafer type

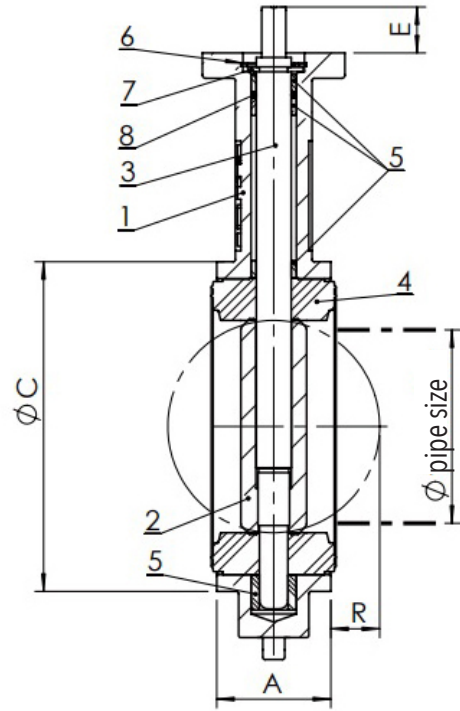
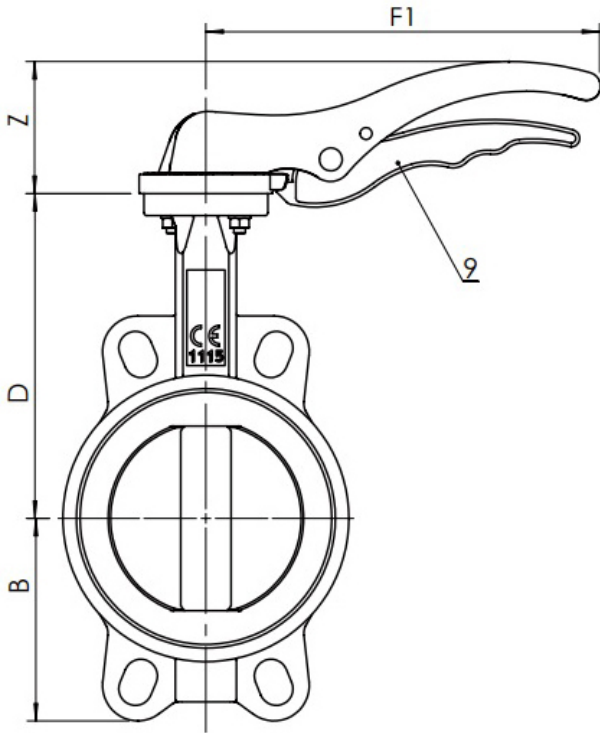

DN	A	Ø C	D	B	F1	Z	R	D min pipe size	Weight with lever kg	Torque (Nm) with DP in bar			
										3	6	10	16
25	33	65	104	51	192	68	---	---	1,7	2,9	3,1	3,3	3,4
32	33	73	110	56	192	68	1	12	1,7	4,7	5,1	5,4	5,7
40	33	82	116	63	170	50	5	27	1,8	7,8	8,4	8,8	9,2
50	43	89	126	62	170	50	5	31	2,1	11,3	12	13	13
65	46	102	136	69	170	50	9	45	2,4	17	18	20	21
80	46	118	150	90	206	69	17	65	3,2	23	25	26	28
100	52	150	170	106	206	69	26	90	4,3	33	36	40	44
125	56	174	180	119	285	90	34	110	6,3	48	54	61	68
150	56	205	200	131	285	90	50	146	7,8	68	78	88	99
200	60	260	230	166	400	72	71	194	15,0	120	134	148	162
250	68	318	266	202	530	72	91	241	23,5	189	212	234	257
300	78	376	292	235	---	---	112	291	---	290	316	342	367
350	78	406	335	257	---	---	128	324	---	298	347	396	550

VFL LUG type

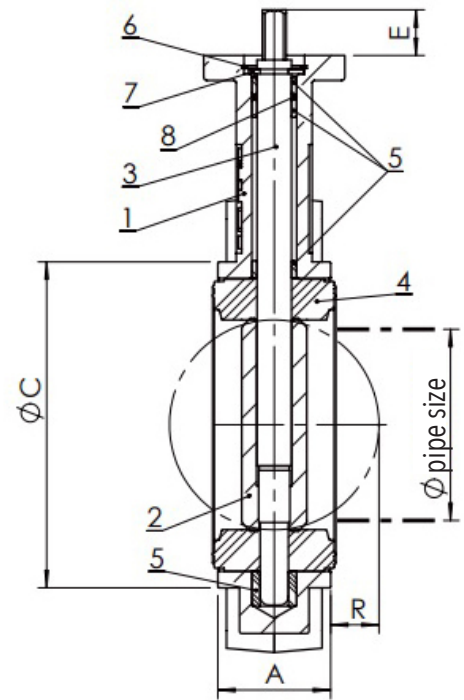
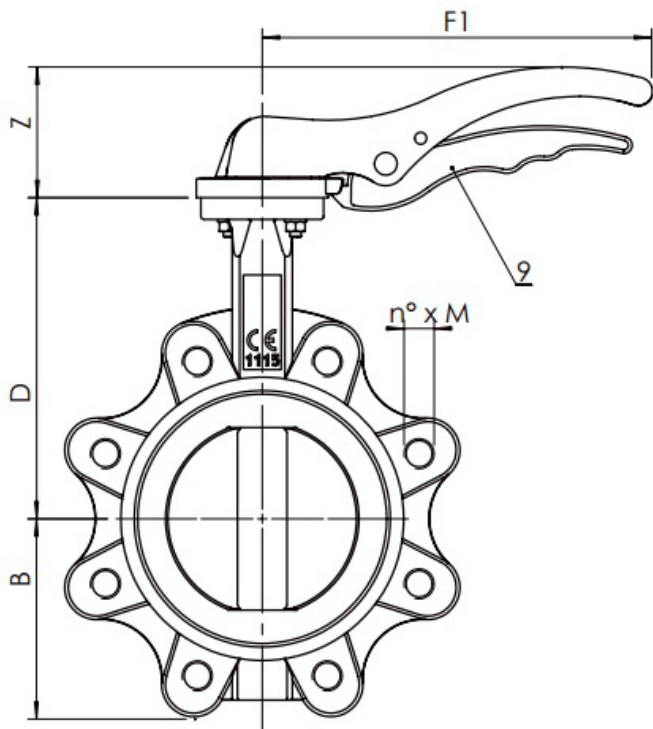

DN	A	ø C	D	B	F1	Z	R	D min pipe size	Weight with lever kg	Torque (Nm) with DP in bar			
										3	6	10	16
25	33	65	104	51	192	68	---	---	2,6	2,9	3,1	3,3	3,4
32	33	73	110	56	192	68	1	12	2,6	4,7	5,1	5,4	5,7
40	33	82	116	63	170	50	5	27	2,3	7,8	8,4	8,8	9,2
50	43	89	126	62	170	50	5	31	3,2	11,3	12	13	13
65	46	102	136	69	170	50	9	45	4,1	17	18	20	21
80	46	118	150	90	206	69	17	65	5,4	23	25	26	28
100	52	150	170	106	206	69	26	90	6,7	33	36	40	44
125	56	174	180	119	285	90	34	110	9,6	48	54	61	68
150	56	205	200	131	285	90	50	146	10,8	68	78	88	99
200	60	260	230	166	400	72	71	194	21,1	120	134	148	162
250	68	318	266	202	530	72	91	241	32,7	189	212	234	257
300	78	376	292	235	---	---	112	291	41,2	290	316	342	367
350	78	438	368	267	---	---	128	324	---	298	347	396	---
400	102	489	400	297	---	---	144	379					
450	114	539	422	318	---	---	163	428					
500	127	594	480	355	---	---	182	475					
600	154	695	562	444	---	---	219	573					

EXAMPLES

Motorized butterfly valves with pneumatic actuator



with electric actuator



ACCESSORIES

Gear box



Limit switch

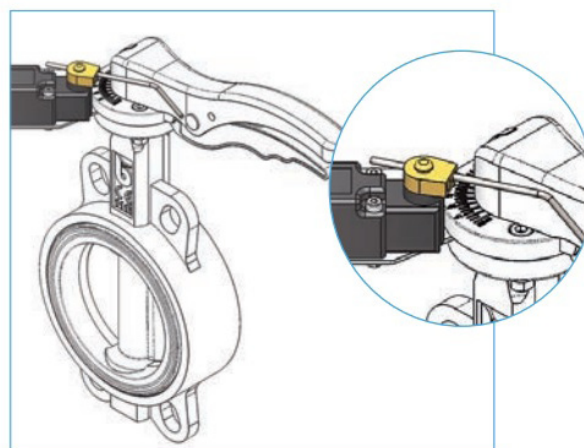

All the reported data are subject to be changed without notice.

form181011

econex

Econex s.r.l. - Via Francesco De Sanctis, 53 - I-20141 Milano
Tel. +39 0289502912 - Fax +39 028463084 - www.econex.it - info@econex.it