

Pressure regulator and zero governor series RV-R...SM/ZM

These series of regulators can be used on metering installations, commercial and industrial installation or on OEM applications on burner or boiler trains, for gases belonging to the first, second and third family.

RV is a straight-thru flow design, while R...SM/ZM of regulators are have a balanced valve design.

All models are approved according to norms EN 88 with Product-ID-Number, as well as to Gas Appliances Directive 90/396/EEC.



TECHNICAL FEATURES

Valve body and cover	Die-caste aluminium
Primary and secondary seat disc	Buna "N"
Threaded connections	Rp 3/8 ÷ 2 according to EN 10226
Ambient temperature	-15 ÷ +80°C
Max. inlet pressure	100 ÷ 360 mbar
Regulation range	From 5 mbar to 150 mbar by means of a wide range of springs

FEATURES

- ISO 7-1 and EN 10226-1 threads
- Installation on horizontal or vertical position
- 1/8 threaded breather port for venting away to atmosphere

RV SERIES

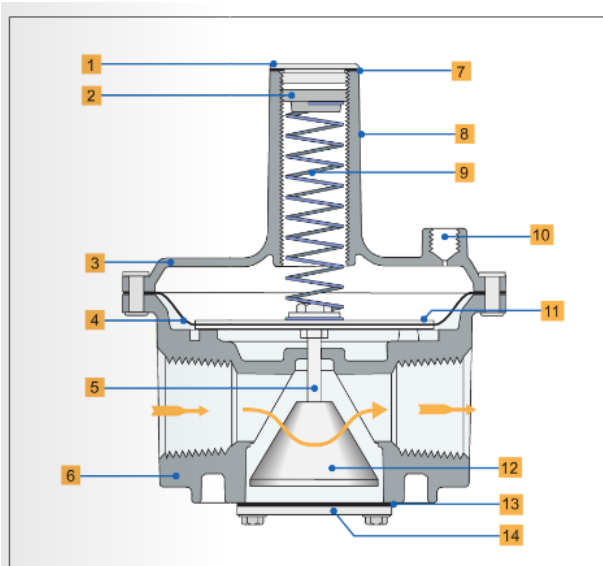

- 1** Welch Plug/Seal Cap
- 2** Vibration Resistant Adjusting Screw
- 3** Top Housing
- 4** Diaphragm
- 5** Stem
- 6** Bottom Housing
- 7** Seal Cap Gasket
- 8** Stack
- 9** Spring
- 10** Vent Connection
- 11** Diaphragm Plates
- 12** Valve
- 13** Bottom Plate Gasket
- 14** Bottom Plate

NOTE: Diagrams are graphical representations only and may differ from actual product.

MODELS

Item	Diameter Rp	Max. inlet pressure	Regulation range	Air capacity at 2,5 mbar pressure drop
RV47LM	3/8 - 1/2	100	2,5 - 30 mbar	2 m ³ /h
RV48LM	1/2 - 3/4	100	2,5 - 30 mbar	4,8 m ³ /h
RV52M	1/2	100	5 - 56 mbar	8 m ³ /h
RV53M	3/4	200	5 - 76 mbar	12 m ³ /h
RV61M	1	200	5 - 76 mbar	25 m ³ /h
RV81M	1.1/4	200	5 - 105 mbar	40 m ³ /h
RV81M	1.1/2	200	5 - 105 mbar	40 m ³ /h
RV91M	2	200	5 - 105 mbar	70 m ³ /h

DIMENSIONS

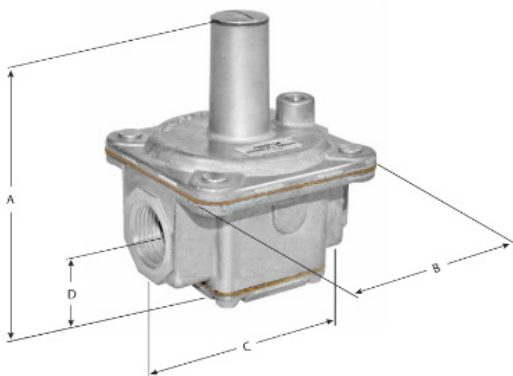

Item	Diam. Rp	Dimension mm				Weight (Kg)
		A	B	C	D	
RV47LM	3/8-1/2	57	16	75	57	0,17
RV48LM	1/2-3/4	70	19	86	76	0,26
RV52M	1/2	120	79	83	32	0,45
RV53M	3/4	132	95	99	35	0,72
RV61M	1	165	138	112	42	1,1
RV81M	1.1/4	213	152	178	52	2,2
RV81M	1.1/2	213	152	178	52	2,2
RV91M	2	270	181	232	63	3,7

GOVERNORS R...SM and ZERO GOVERNORS R...ZM

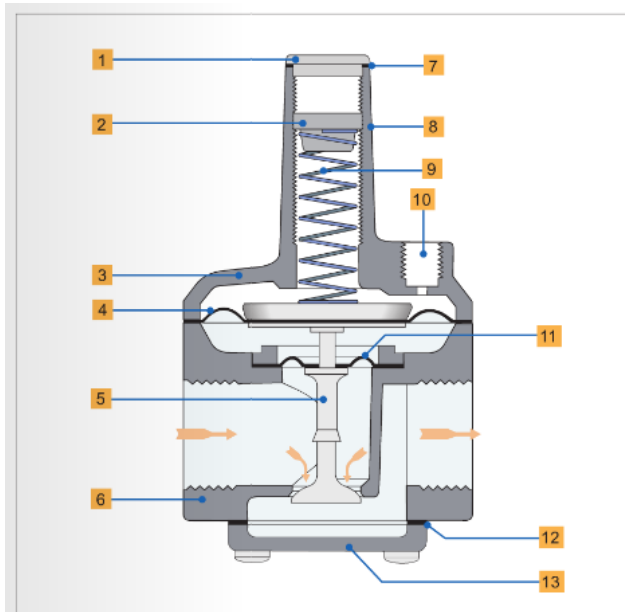

- 1** Welch Plug/Seal Cap
- 2** Vibration Resistant Adjusting Screw
- 3** Top Housing
- 4** Regulating Diaphragm
- 5** Stem & Valve
- 6** Bottom Housing
- 7** Seal Cap Gasket
- 8** Stack
- 9** Spring
- 10** Vent Connection
- 11** Balancing Diaphragm
- 12** Bottom Plate Gasket
- 13** Bottom Plate

MODELS

Item	Diameter Rp	Max. inlet pressure	Regulation range	Air capacity at 2,5 mbar pressure drop
R400SM	3/8 - 1/2	360 mbar	2,5 - 55 mbar	2 m ³ /h
R500SM	1/2 - 3/4	360 mbar	2,5 - 55 mbar	4,8 m ³ /h
R600SM	3/4 - 1	360 mbar	2,5 - 55 mbar	8 m ³ /h
R400ZM	3/8 - 1/2	100 mbar	-2,5 - 3,5 mbar	2 m ³ /h
R500ZM	1/2 - 3/4	100 mbar	-2,5 - 3,5 mbar	4,8 m ³ /h
R600ZM	3/4 - 1	100 mbar	-2,5 - 3,5 mbar	8 m ³ /h

DIMENSIONS

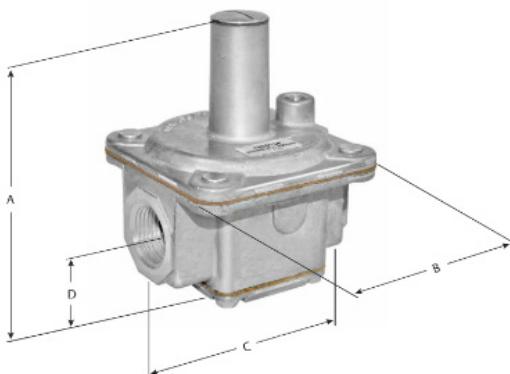

Item	Diam. Rp	Dimension mm				Weight (Kg)
		A	B	C	D	
R400SM (ZM)	3/8-1/2	83	51	51	24	0,2
R500SM (ZM)	1/2-3/4	119	79	76	30	0,4
R600SM (ZM)	3/4-1	145	99	103	38	0,7



WARNING

Installation must be carried out exclusively by skilled and authorized service technicians.

1. INSTALLATION

- 1.1 Make sure that all operating data indicated on the pressure stabilizer label correspond to those of the system.
- 1.2 Remove the protection plugs from the stabilizer.
- 1.3 Before installing the stabilizer make sure that the pipeline is free from impurities and perfectly aligned with the stabilizer body. The pipeline must be vibration-free.
- 1.4 Use only sealing compounds approved for gas. Apply sparingly, only to outer threads.
- 1.5 To avoid body breach, do not screw the piping on stabilizer too tight.
- 1.6 The direction of the gas flow must coincide with the arrow on the housing.
- 1.7 Stabilizer can be installed both in horizontal and vertical position; max. performance will be reached by mounting the diaphragm horizontally and spring seat upwards.
- 1.8 Do not use spring retaining housing as lever, always use appropriate wrenches.
- 1.9 The equipment is maintenance-free