



Design and applications

The DDM-EM measuring orifice measures and monitors the flow of gases and liquids.

The device works according to the principle of differential pressure. The differential pressure at the orifice is proportional to the square of the volume rate of flow through the pipeline. The user mounts the orifice between flanges or with Rp pipe unions into the conduit. The unimpeded, straight tube length has to be 6 DN before and 4 DN behind the mounting position.

The EM gauge contains a rugged and uncomplicated diaphragm system. The differential pressure generates a unilateral force at the membrane which moves the diaphragm system against the measuring range springs. The resulting displacement is transmitted to the core of an inductive displacement transducer via an axial rod. The built-in electronics evaluates this deflection and transforms them into direct display, limit value switches and output signal.

The applications of DDM-EM are engineering and process technology such as the monitoring of coolant streams in plants.

DDM-EM



- **installation between flanges as per DIN EN 1092-1, internal and external threads as per DIN EN ISO 228 or with pipe union as per DIN EN 10226-1 (ISO 7-1)**
- **one device for all installation situations and flow directions**
- **suitable for liquids and gases**
- **no moving parts, wear-free**
- **calibration acc. to customer specifications**
- **4 ... 20 mA / 0 ... 10 V output**
- **digital LCD display in m³/h**
- **optionally**
 - **wall attachment installation**
 - **limit value switches**
 - **other display units**

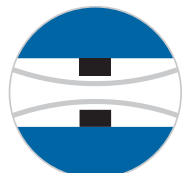

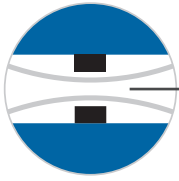

DDM-EM

Differential pressure flow meters

Type series

DDM-EM DN	measuring orifice sandwiched between flanges
DDM-EM Rp	measuring orifice with pipe fitting
DDM-EM Gi	measuring orifice with internal threads
DDM-EM Ga	measuring orifice with external threads

Technical data

Measuring principle	differential pressure measurement on the orifice DDM-EM
Perm. ambient temperature	-10 ... + 70 °C
Perm. media temperature *)	standard -10 ... + 70 °C max. 130 °C (insulated line) optionally HT-Type above 130 °C
Protection class	IP 65 acc. to DIN EN 60529
Measurement accuracy	5 % of measurement range end value
Display unit	electronic differential pressure transmitter with 4 digit LCD display and 4 ... 20 mA, 0 ... 10 V output
In-between flange (DN)	for PN 10/PN 16 flanges acc. to DIN EN 1092-1 shape A & B
Pipe union (Rp)	two-part pipe fitting: insert with cylindrical internal thread acc. to DIN EN 10226-1 (ISO 7-1)
External thread (Ga)	cyl. external thread acc. to DIN EN ISO 228
Internal thread (Gi)	cyl. internal thread acc. to DIN EN ISO 228

*) media must not freeze

Materials

DDM-EM DN	
Ring	S355, optionally 1.4571
Corrosion protection	Epoxy powder coating, traffic blue (RAL 5017) glossy
Corrosion class	C3
Orifice	1.4571
DDM-EM Rp, Gi, Ga	
Pipe union (Rp)	malleable cast iron, zinc plated
Orifice and ring	brass
Gaskets	NBR
Connection between orifice and indicator	
Straight screw-in fitting 1/4"	brass, nickel plated, 1.4571 on request
Screw fitting G 1/4" dia. Ø 8	brass, nickel plated, 1.4571 on request
Cutting ring, union nuts	steel, zinc plated, 1.4571 on request
Steel sealing	steel, zinc plated, with NBR seal
Indicator EM	
Parts in contact with media	FKM, NBR, brass
Measuring diaphragm	NBR
Housing	polyamide PA 6.6

other materials on request

Dimensions for DDM-EM DN

DN *)	d4	H
50	102	282
65	122	302
80	138	318
100	158	338
125	188	368
150	212	392
200	268	448

*) inside diameter is made as specified by the pipe inner diameter

Dimensions for DDM-EM Rp

Rp *)	L1	L2	SW	H
1/4	80	124	41	200
3/8	80	128	46	203
1/2	80	128	46	203
3/4	80	128	50	205
1	80	136	60	210
1 1/4	80	146	70	215
1 1/2	80	149	70	215
2	90	164	85	222

*) inside diameter is made as specified by the pipe inner diameter

Dimensions for DDM-EM Gi/ Ga

Gi *)	L	SW	H
1/4	80	41	200
3/8	80	46	203
1/2	80	46	203
3/4	80	50	205
1	80	60	210
1 1/4	80	70	215
1 1/2	80	70	215
2	90	85	222

*) inside diameter is made as specified by the pipe inner diameter

DDM-EM Gi

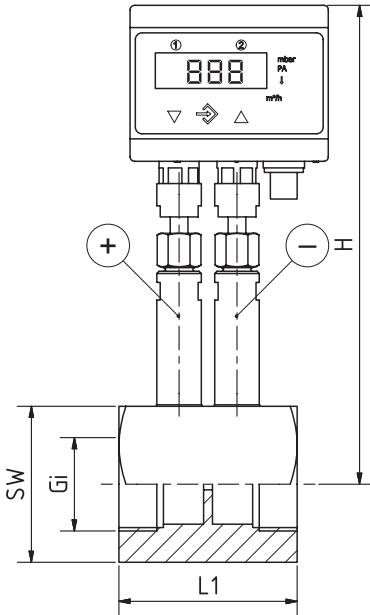

DDM-EM Ga / Rp

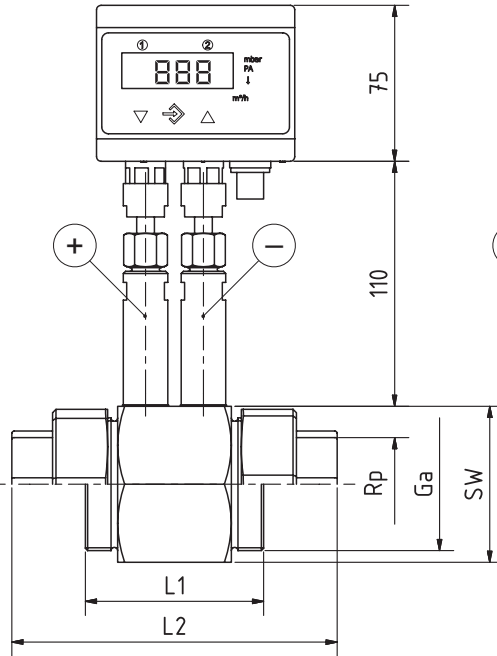

DDM-EM DN

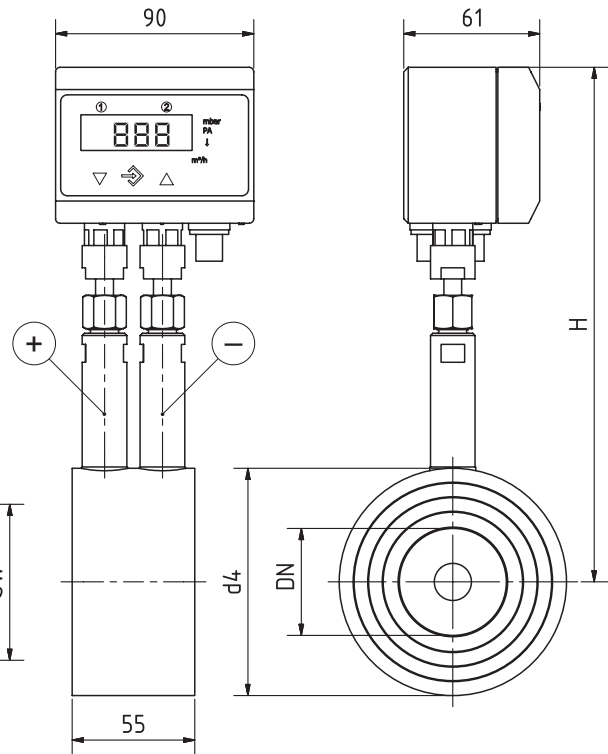

Flow rates for water

Connection: screwed pipe union /
internal thread / for external thread

Rp / Ga / Gi	smallest measuring range [m ³ /h] H ₂ O		largest measuring range [m ³ /h] H ₂ O	
¼	0,075	- 0,3	0,3	- 1,2
⅓	0,1	- 0,4	0,575	- 2,3
½	0,175	- 0,7	1,125	- 4,5
¾	0,325	- 1,3	2,125	- 8,5
1	0,5	- 2	3,375	- 13,5
1¼	0,875	- 3,5	6	- 24
1½	1,25	- 5	8	- 32
2	1,875	- 7,5	13	- 52

in-between ranges possible

Flow rates for air

Connection: screwed pipe union /
internal thread / for external thread

Rp / Ga / Gi	smallest measuring range [m ³ /h] air ¹⁾		largest measuring range [m ³ /h] air ¹⁾	
¼	0,75	- 3	2	- 8
⅓	1,25	- 5	3,5	- 14
½	1,5	- 6	5,25	- 21
¾	2	- 8	11,25	- 45
1	3	- 12	13,5	- 54
1¼	6	- 24	27	- 108
1½	8,75	- 35	37,5	- 150
2	12,5	- 50	67,5	- 270

¹⁾at STP (0 °C and 1013 mbar) in-between ranges possible

Connection for in-between flange assembly

DN	smallest measuring range [m ³ /h] H ₂ O		largest measuring range [m ³ /h] H ₂ O	
40	0,85	- 5	5,35	- 32
50	1,75	- 7	13	- 52
65	3	- 12	19,5	- 78
80	4,5	- 18	29,5	- 118
100	7	- 28	46	- 184
125	11	- 44	72	- 288
150	16	- 64	103,25	- 413
200	28,25	- 113	183,75	- 735

in-between ranges possible

Connection for in-between flange assembly

DN	smallest measuring range [m ³ /h] air ¹⁾		largest measuring range [m ³ /h] air ¹⁾	
40	5,8	- 35	25	- 150
50	13,5	- 54	67,5	- 270
65	20,25	- 81	125	- 500
80	30	- 120	187,5	- 750
100	52,5	- 210	212,5	- 1080
125	90	- 360	437,5	- 1750
150	112,5	- 450	650	- 2600
200	187,5	- 750	1000	- 4000

¹⁾at STP (0 °C and 1013 mbar) in-between ranges possible

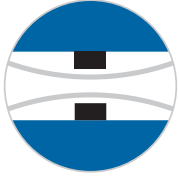

DDM-EM

Differential pressure flow meters

Pressure losses and pressure resistance DDM-EM

Pressure loss	approx. 30 ... 60 % of differential pressure *)
Pressure resistance	16 bar

*) to be taken from the tender on request

Technical data display unit EM

Nominal voltage	24 V DC/AC
Perm. operating voltage	12 ... 32 V DC/AC
Output signal	4 ... 20 mA, optionally: 0 ... 20 mA, 0 ... 10 V DC three conductor
Power consumption	approx. 2 W/VA
Limit value switches	2 potential-free relay switches programmable as NO contact or NC contact
Display unit	4 digit LCD
Electrical connections	2 x round connectors M12 Connector 1: for supply and analogue output signal (5 pin, male) Connector 2: for limit value switches (4 pin, male) Connection is made via cable Cable length 2m, optionally 5m, 12m, 15m
Permissible media temperature ¹⁾	-10 ... +70 °C

¹⁾ media must not freeze

Programming display unit EM

Damping	0.0 ... 100.0 s (step response time 10/90 %), separated also for display
Switch output 1 / 2	switch-off point, switch-on point, response time (0 ... 100 s), function (NC contact/ NO contact)
Unit of measure	m ³ /h, bar, kPa, others on request
Zero suppression	0 ... 1/3 of the basic measuring range ¹⁾
Measurement range start/end	set as required within the basic measurement range ²⁾
Zero point correction	± 1/3 of the basic measuring range ³⁾
Curve conversion	square root, optionally: linear
Password	001 ... 999 (000 = no password protection)

¹⁾ measured values around zero are set to zero

(e.g. for creep flow suppression)

²⁾ Max. effective spread 4:1

³⁾ zero point correction for compensation in differing installation locations

Connection schematic and switching function

Connector 1: Power Supply and Output

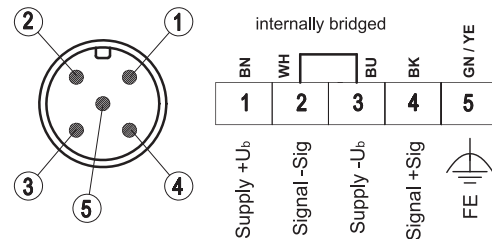

Connector 2: Switching contact (NO)

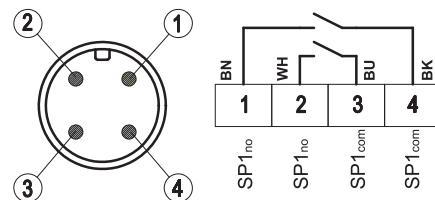

Proper use

The user is responsible for assessing the suitability of the flow meters for his case of application, for use as prescribed, and for material compatibility regarding the fluid product used in his process. The manufacturer shall not be liable for any damage arising from incorrect or improper use of the devices.

The equipment from **Kirchner und Tochter** has been tested in compliance with applicable CE-regulations of the European Community. The respective declaration of conformity is available on request. Subject to change without notice. The current valid version of our documents can be found at: www.kt-flow.de

The **Kirchner und Tochter** QM-System is certified in accordance with DIN-EN-ISO 9001:2015. The quality is systematically adapted to the continuously increasing demands.